VISTA-20AMT3

SECURITY SYSTEM

**INSTALLATION
INSTRUCTIONS**



RECOMMENDATIONS FOR PROPER PROTECTION

The Following Recommendations For The Location Of Fire And Burglary Detection Devices Help Provide Proper Coverage For The Protected Premises.

Recommendations For Smoke And Heat Detectors

With regard to the number and placement of smoke/heat detectors, we subscribe to the recommendations contained in the National Fire Protection Association's (NFPA) Standard #72 noted below.

Early warning fire detection is best achieved by the installation of fire detection equipment in all rooms and areas of the household as follows: For minimum protection a smoke detector should be installed outside of each separate sleeping area, and on each additional floor of a multi-floor family living unit, including basements. The installation of smoke detectors in kitchens, attics (finished or unfinished), or in garages is not normally recommended.

For additional protection the NFPA recommends that you install heat or smoke detectors in the living room, dining room, bedroom(s), kitchen, hallway(s), attic, furnace room, utility and storage rooms, basements and attached garages.

In addition, we recommend the following:

- Install a smoke detector inside every bedroom where a smoker sleeps.
- Install a smoke detector inside every bedroom where someone sleeps with the door partly or completely closed. Smoke could be blocked by the closed door. Also, an alarm in the hallway outside may not wake up the sleeper if the door is closed.
- Install a smoke detector inside bedrooms where electrical appliances (such as portable heaters, air conditioners or humidifiers) are used.
- Install a smoke detector at both ends of a hallway if the hallway is more than 40 feet (12 meters) long.
- Install smoke detectors in any room where an alarm control is located, or in any room where alarm control connections to an AC source or phone lines are made. If detectors are not so located, a fire within the room could prevent the control from reporting a fire or an intrusion.

THIS CONTROL COMPLIES WITH NFPA REQUIREMENTS FOR TEMPORAL PULSE SOUNDING OF FIRE NOTIFICATION APPLIANCES.

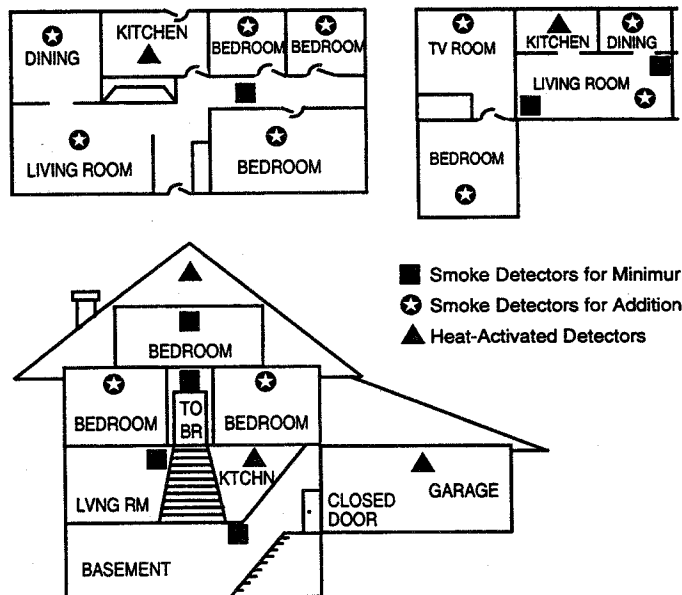

Recommendations For Proper Intrusion Protection

For proper intrusion coverage, sensors should be located at every possible point of entry to a home or commercial premises. This would include any skylights that may be present, and the upper windows in a multi-level building.

In addition, we recommend that radio backup be used in a security system so that alarm signals can still be sent to the alarm monitoring station in the event that the telephone lines are out of order (alarm signals are normally sent over the phone lines, if connected to an alarm monitoring station).

TABLE OF CONTENTS

Section 1.	GENERAL DESCRIPTION	7
Section 2.	INSTALLING THE CONTROL	10
	Mounting the Cabinet	10
	Installing the Lock (if used)	10
	Mounting the Control's Circuit Board Alone in the Cabinet	11
	Mounting Control and RF Receiver Circuit Boards Together in the Cabinet	11
	Standard Phone Line Connections	12
	Wiring the AC Transformer	12
	Installing the Back-Up Battery	13
	Earth Ground Connections	13
Section 3.	INSTALLING REMOTE KEYPADS	14
	Keypads That May Be Used	14
	Wiring The Keypads	14
	Mounting The Keypads	15
	Using A Supplementary Power Supply To Power Additional Keypads	15
	Preliminary Check-Out Procedure	16
Section 4.	BASIC HARD-WIRED ZONES 1-8	17
	Installing the Hard-Wired Zones	17
	Common Characteristics For Zones 1-8	17
	Wiring Burglary and Panic Devices to Zones 1-8	17
	Wiring 2-Wire Smoke Detectors to Zone 1	17
	"Verify" Operation of 2-Wire Smoke Detectors in Zone 1	17
	Turning Off Fire Alarm Sounding	18
	Wiring 4-Wire Smoke/Combustion Detectors on Zones 2-7	18
	Wiring 2-Wire Latching Type Glass Break Detectors on Zone 8	19
	Check-Out Procedure for Hard-Wired Zones	20
Section 5.	WIRED ZONE EXPANSION (4219, 4229)	21
	Installing Zone Expansion Units	21
	Connections and Set-Up	21
	Check-Out Procedure for Wired Expansion Zones	22
Section 6.	WIRELESS ZONE EXPANSION (5800 SYSTEM)	23
	General Information	23
	Receiver Supervision	23
	House Identification	23
	Installing the 5881/5882 RF Receiver	23
	RF System Installation Advisories	23
	Installation and Set-Up of the 5881/5882 Receiver	24
	Installing the 5800TM Module	25
	Mounting the 5800TM Module	25
	5800TM Wiring Connections	25
	5800 Series Transmitters	25
	General	25
	Transmitter Supervision	25
	Transmitter Input Types	26
	Transmitter Battery Life	26
	Using the Transmitter Sniffer Mode	26
	5800 Series Transmitters Table	27
Section 7.	RELAY OUTPUTS & POWERLINE CARRIER DEVICES	29
	Relay/Powerline Carrier Device Basics	29
	Nos. 4204 And 4229 Output Relay Modules	29
	4204/4229 Setup	29
	Powerline Carrier Devices	30
	Wiring Connections	31

Section 8.	4285 & 4286VIP PHONE MODULES	32
	Installing the Phone Module	32
	General Information	32
	Mounting The Phone Module	32
	Phone Module Wiring	33
	Caller ID Units	33
	Checking the Operation of the 4285 or 4286VIP Phone Module	35
Section 9.	EXTERNAL SOUNDERS	36
	Compatible Sounders	36
	Sounder Connections	37
	Testing the Sounder	37
Section 10.	LONG RANGE RADIO	38
	General Information	38
	Connection	38
Section 11.	REMOTE KEYSWITCH	39
	Installing the Keyswitch	39
	Remote Keyswitch Connections	39
	Programming for the Remote Keyswitch	41
	Keyswitch Operation	42
Section 12.	AUDIO ALARM VERIFICATION (AAV) UNIT	43
	General Information	43
	Wiring Connections	43
Section 13.	FINAL POWER UP	45
	Earth Ground Connections	45
	Connecting the Back-Up Battery	45
	Calculating the Battery Size Needed	45
	Making the Battery Connections	46
	Auxiliary Device Current Draw Worksheet	46
Section 14.	MECHANICS OF PROGRAMMING	47
	General Programming Information	47
	Entering Program Mode	47
	Programming a Data Field	47
	Reviewing a Data Field/Erasing an Entry in a Data Field	48
	Interactive Mode Programming (*56, *80, *82, and *83)	48
	Loading Factory Defaults	48
	Programming System Setup Fields	48
	Exiting the Programming Mode	48
Section 15.	ZONE RESPONSE TYPE DEFINITIONS	49
Section 16.	DATA FIELD DESCRIPTIONS	51
Section 17.	ZONE PROGRAMMING (*56 Menu Mode)	61
Section 18.	OUTPUT DEVICES (*80 Menu Mode)	65
Section 19.	ZONE LISTS (*81 Menu Mode)	69
Section 20.	ALPHA DESCRIPTOR PROGRAMMING (*82 Menu Mode)	70
	Zone Descriptors	70
	Programming Zone Descriptors (program Menu Mode *82)	70
	Adding Custom Words	73
	Alpha Vocabulary List (For Entering Zone Descriptors)	74
	Character (ASCII) Chart	74
Section 21.	USING SEQUENTIAL MODE (*83 Menu Mode)	75
Section 22.	REMOTE PROGRAMMING AND CONTROL (DOWNLOADING)	78
	General Information	78
	Equipment Required	78

Initial Download	78
Remote Programming Information	79
Remote Programming Advisory Notes	79
Section 23. SYSTEM COMMUNICATION	80
Report Code Formats	80
Table of Contact ID Codes	82
Section 24. SYSTEM OPERATION	83
Security Codes	83
Keypad Functions	84
Trouble Conditions	86
Section 25. TESTING THE SYSTEM	87
Test Procedure	87
To the Installer	88
Section 26. TROUBLESHOOTING GUIDE	89
Contacting Technical Support In The Event Of Problems	91
REGULATORY AGENCY STATEMENTS	92
Section 27. SPECIFICATIONS & ACCESSORIES	93
Specifications	93
Accessories (Compatible Devices)	95
APPENDIX A. 5800 RF System Wireless Transmitters, Input Loop Identification Diagrams	96
Index	97
Limitations Of This Alarm System	102
Summary Of Connections	103
Limited Warranty	Back Cover
Programming Form	Insert

LIST OF FIGURES

Figure 1. Installing the Cabinet Lock	10
Figure 2. Mounting The PC Board	11
Figure 3. Mounting the PC Board & RF Receiver Together in the Cabinet... ..	11
Figure 4. Telephone Line Connections	12
Figure 5. Connection of 4300 Transformer to the Control Board	13
Figure 6. Keypad Connections to the Control Board	15
Figure 7. Using a Supplementary Power Supply	16
Figure 8. 2-Wire Smoke Detector Connected to Zone 1	18
Figure 9. 4-Wire Smoke Detector Connections (Zones 2-7)	18
Figure 10. Glass Break Detector Connections to Zone 8	19
Figure 11. Wiring Connection, 4219 & 4229 (4229 shown)	21
Figure 12. 5881/5882 RF Receiver (cover removed)	24
Figure 13. 4229 Connections To Control	30
Figure 14. 4204 Connections To Control	30
Figure 15. 4300 Transformer Wiring Connections	31
Figure 16. 4285 Phone Module Wiring Connections	34
Figure 17. Typical Sounder Wiring	37
Figure 18. Long Range Radio Connections	38
Figure 19A. Keyswitch Wiring (4300 Interface Transformer not used)	40
Figure 19B. Keyswitch Wiring (4300 Interface Transformer also used)	40
Figure 20. Connection of AAV Unit When Not Using a 4285 Phone Module .	44
Figure 21. Connection of AAV Unit When Also Using a 4285 Phone Module	44
Figure 22. VISTA-20AMT3 Summary of Connections	103

CONVENTIONS USED IN THIS MANUAL

MAIN SECTION TITLES ARE SHOWN IN REVERSE TYPE

Before you begin using this manual, it is important that you understand the meaning of the following symbols (icons).

	These notes include specific information which must be followed if you are installing this system for a UL Listed application.
---	--

	These notes include information that you should be aware of before continuing with the installation, and which, if not observed, could result in operational difficulties.
---	--

	This symbol indicates a critical note that could seriously affect the operation of the system, or could cause damage to the system. Please read each warning carefully. This symbol also denotes warnings about physical harm to the installer.
---	---

Enter Zn Num. (00 = Quit) 01
--

Many system options are programmed in an interactive mode by responding to Alpha keypad display prompts. These prompts are shown in a double-line box.

***56**

When programming the system, data fields are indicated by a "star" (*) followed by the data field number.

PRODUCT MODEL NUMBERS: Unless noted otherwise, references to specific model numbers represent Ademco products.

	Whenever it becomes necessary to disconnect power in order to add a module or keypad, always disconnect the battery and then the AC transformer in that order. After installation has been completed, connect the AC transformer first followed by connection of the battery.
---	---

Section 1. GENERAL DESCRIPTION

The VISTA-20AMT3 is a security system control that supports up to 38 zones, using basic hard-wired, wired expansion, and/or wireless zones, plus 3 keypad activated zones.

Basic Hardwired Zones

Provides 8 basic hardwired zones having the following characteristics:

- EOLR supervision supporting N.O. or N.C. sensors
- Programmable response time (10, 350, or 700 milliseconds)
- Up to sixteen 2-wire smoke detectors on zone 1
- 4-wire smoke or heat detectors on zones 2 through 7 (as many as can be powered from AUX power on the control)
- Up to fifty 2-wire latching type glassbreak detectors on zone 8 with auto reset

Optional Expansion Zones (up to 30 total, wired and wireless)

Wired Expansion:

Supports up to 8 additional wired zones using a 4219 expansion module or 4229 expansion/relay module. These zones have the following characteristics:

- EOLR supervision supporting N.O. or N.C. sensors
- 300–500 msec normal response with an option for fast (10–15 msec) response on loop A (first expansion zone)

Wireless Expansion:

Supports up to 30 wireless zones (less if using wired expansion zones).

- Requires the use of a 5881(5882 in Canada) type RF Receiver, as indicated below

<u>Receiver Model</u>	<u>No. of Zones</u>
5881L/5882L	Up to 8
5881M/5882M	Up to 16
5881H/5882H	Up to 30

- Requires the use of 5800 series wireless transmitters

Remote Keypads

Up to 8 of any of the following keypads may be used in the installation:

Fixed-Word Keypad: 6128AMT3.

Alpha Keypad: 6139AMT3 (2-line alphanumeric displays)



For programming from a keypad, a 6139AMT3 2-line Alpha keypad must be connected, but need not remain in the system after programming has been completed.

Security Codes

- One installer code for entire system (user 1)
- One Master code for entire system (user 2)
- 12 secondary user codes (users 3–14)
- One baby-sitter code (user 15)
- One duress code (user 16)



Baby-sitter Code: A special code that can only be used to disarm the system if that particular code (or the installer code) was used to arm it.

Duress Code: An emergency code which, when entered by *any* user to disarm or arm the system, will send a silent duress message to the central station.

Keypad Panic Keys

- Up to 3 programmable panic key functions are provided.
- Designated as Zones 95, 96, 99
- Activated by wired & wireless keypads
- Distinguished by subscriber ID number

Zone Monitor Feature

- The control will sense a high resistance in the loops on hard-wired zones 2–8 if it is present, and will display a trouble message (rather than an alarm) for the affected zone when the system is in the disarmed mode. This feature also prevents the system from being armed while this high resistance condition exists.

Exit Error False Alarm Prevention Feature

- Enables the system to determine the difference between an actual alarm and an alarm caused by leaving an Entry/Exit or Interior zone open after the exit delay expires. If not disarmed in time, an alarm will sound and an “Exit Error” report sent to the central station.
- An Exit Alarm condition will also occur if an Entry/Exit or Interior zone re-opens within 2 minutes after the end of an exit delay.

Optional Output Relays and Powerline Carrier Devices (X-10 type)

- Up to 4 relays using one 4204 Relay Module
- Up to 2 relays using one 4229 Zone/Relay Module
- Up to 8 Powerline Carrier devices (you must subtract the number of relay outputs actually used by the 4204 or 4229 modules, if used)
- Actions programmable to respond to zone activity or manual keypad entries



Powerline Carrier devices require the use of optional 4300 transformer module instead of the supplied 1321 AC transformer.

Optional Phone Module

- Supports the Ademco 4285/4286 Phone Module
- Provides access to the system via on premises or off-premises phones for arming, disarming, etc., plus control of relay outputs and Powerline Carrier devices.

Paging Feature

- If programmed, the paging feature permits up to 16-digits to be sent to a pager for user-determined messaging, followed by a system generated 7-digit condition code which indicates the type of condition that has occurred and the user number or zone number of occurrence.

Audio Alarm Verification Option

- Provides a programmable Audio Alarm Verification (AAV) option which can be used in conjunction with an output relay to permit voice dialog between an operator at the central station and a person at the premises.
- Requires the use of optional AAV unit, such as Eagle model 1241.



The AAV option may not be used in UL installations.

Optional Long Range Radio

- Allows all messages that have been programmed to go to the primary telephone number to be reported additionally to a 7720PLUS or 7820 radio. Check availability of these models.

Built-in Telephone Line Monitoring Option

- The telephone line voltage can be monitored to supervise the phone line connection. **The panel must be connected to a proper earth ground or you will get a false line cut indication if this feature is enabled.**
- The loss of the line can optionally cause a local display, or a display and trouble sound.

Event Logging

- Event Logging feature keeps a record of selected events in a history log (up to 48 events). All control and readout from the log is done via Ademco V-Link software **only**.

Alarm Output

- Provides a 12VDC, 2 AMP output that can drive the compatible sounders listed in the EXTERNAL SOUNDERS section (assumes a fully charged battery is connected).
- Steady output for Burglary/Panic, or temporal pulse output (3 pulses – pause – 3 pulses – pause – 3 pulses. . .) for Fire.
- Uses current limiting circuitry for protection.

Auxiliary Power Output

- Provides 12VDC, 600 mA maximum. Uses current limiting circuitry for protection.
- This output interrupts for smoke detector reset if 4-wire smoke detectors are used.

Programming

- Programmed options are stored in electrically erasable, non-volatile EEPROM memory (information can be reprogrammed at any time and will not be lost in the event of a power loss).
- The system can be uploaded, downloaded, or controlled via an IBM compatible computer, V-Link software and a HAYES modem specified by Ademco.

Keypad programming consists of:

- Data field programming
- Interactive (menu) mode programming



For programming from a keypad, a 6139 2-line Alpha keypad must be connected, but need not remain in the system after programming has been completed.

Communication Formats Supported

- Ademco Low Speed (Standard or Expanded)
- SESCOA/Radionics (Standard or Expanded)
- Ademco Express
- Ademco Contact ID

Zone Descriptors

You can assign Alpha descriptors to all zones (useful only when using Alpha keypads and/or the 4285/4286 Phone Module).

AC Power Supply

Uses 1321, 110VAC plug-in transformer with 16.5VAC 25VA output, unless Powerline Carrier devices (ex. X-10 type) are used, in which case a 4300 transformer module must be used.

Back-Up Battery

- Rechargeable (Gel type) 12VDC, 4AH minimum.

Section 2. INSTALLING THE CONTROL

This section provides instructions for mounting the control cabinet, and installing the cabinet lock (if used). Also included in this section are instructions for the following:

- Installing the main PC board
- Mounting the 5881 (5882 in Canada) RF Receiver board in the cabinet (if used)
- Standard phone line connections
- Installing the back-up battery in the cabinet
- Connecting the AC transformer
- Making earth ground connections

Mounting the Cabinet

Mount the control cabinet to a sturdy wall using fasteners or anchors (not supplied), in a clean, dry area which is not readily accessible to the general public. Four mounting holes are provided at the back of the cabinet.

If an RF Receiver is being used and you intend to mount its PC board within the cabinet, note the following:

- Do not mount the cabinet on or near metal objects. This will decrease RF range and/or block RF transmissions from wireless transmitters.
- Do not locate the cabinet in an area of high RF interference (revealed by frequent or prolonged lighting of the LED in the receiver after it is operational (random flicker is OK).

Installing the Lock (if used)

Use an Ademco No. N6277 Cam Lock and No. N6277-1 Push-On Clip (Retainer Clip).

Note: The cabinet can be closed and secured without a lock by using 2 screws in the cover's edge.

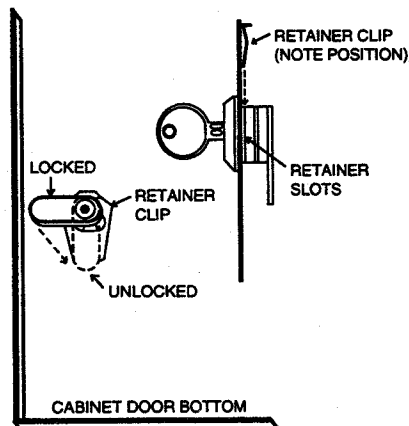

Figure 1. Installing The Cabinet Lock

1. Remove the cabinet door. It is easily removable for servicing and is easily re-installed.
2. Remove the lock knockout from the control cabinet door. Insert the key into the lock. Position the lock in the hole making certain that the latch will make contact with the latch bracket when the door is closed.
3. Hold the lock steady, and insert the retainer clip into the retainer slots. Position the clip as illustrated in order to permit easy removal.



Before installing the cabinet's contents, remove the metal cabinet knock-outs required for wiring entry. Do not attempt to remove the knockouts after the circuit board has been installed.

Mounting The Control's Circuit Board Alone in The Cabinet (Fig. 2)

1. Hang two short Black mounting clips (provided) on the raised cabinet tabs (see Detail B in Fig. 2).
2. Insert the top of the circuit board into the slots at the top of the cabinet. Make sure that the board rests on the correct row (see Detail A).
3. Swing the base of the board into the mounting clips and secure the board to the cabinet with the accompanying screws (see Detail B in Fig. 2).

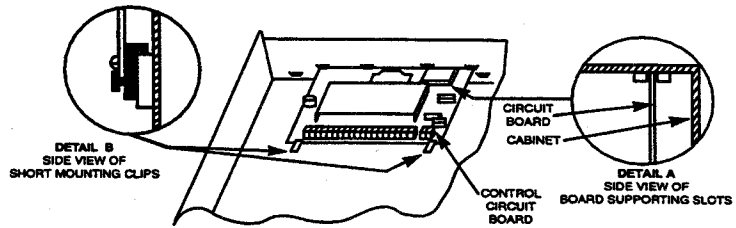

Figure 2. Mounting The PC Board

Mounting Control and RF Receiver Circuit Boards Together, in the Cabinet

1. Hang two short (black) mounting clips (provided with receiver) on the raised cabinet tabs, as shown in Detail B in Figure 3.
2. Insert the top of the receiver board (removed from its own case as described in its instructions) into the slots at the top of the cabinet, as shown in Detail A in Figure 3. Make sure that the board rests on the correct row of tabs, as shown.
3. Swing the base of the board into the mounting clips and secure it to the cabinet with the accompanying screws (see Detail B in Fig. 3).
4. Insert the top of the control's board into the slot in the clips and position two long (red) clips at the lower edge of the board (see Detail C).
5. Swing this board into place and secure it with two additional screws.
6. Insert grounding lugs (supplied with the receiver) through the top of the cabinet into the left-hand terminals of the antenna blocks (at the upper edge of the receiver board) and secure them to the cabinet top with the screws provided, as shown in Detail D.
7. Insert the receiver's antennas through the top of the cabinet, into the blocks' right-hand terminals, and tighten the screws.
8. Refer to the WIRELESS ZONE EXPANSION section for setup and wiring of the receiver.

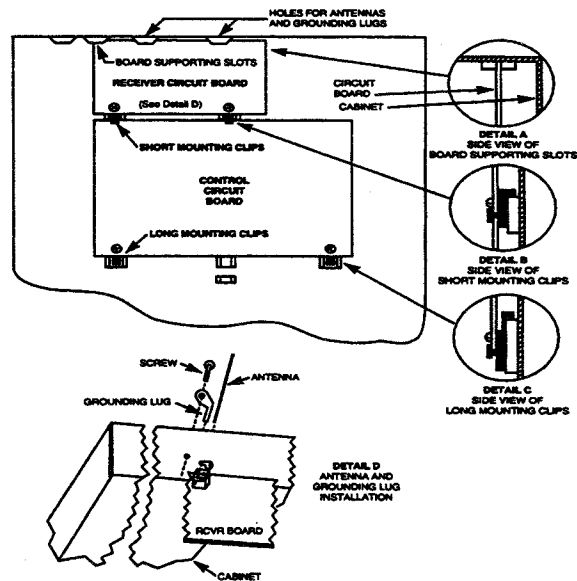

Figure 3. Mounting The PC Board And RF Receiver Together In The Cabinet

Standard Phone Line Connections



The wiring connections shown here are not applicable if the 4285 Phone Module is used. Refer to the 4285 Phone Module section for information regarding phone line connections, which are different than those shown here.

Incoming phone line and handset wiring is connected to the main terminal block (via a RJ31X jack) as follows (also see Figure 4):

Term. 21: Local Handset (TIP – Brown*)

Term. 22: Local Handset (RING – Gray*)

Term. 23: Incoming Phone Line (TIP – Green*)

Term. 24: Incoming Phone Line (RING – Red*)

* Colors of wires in Direct Connect Cord.

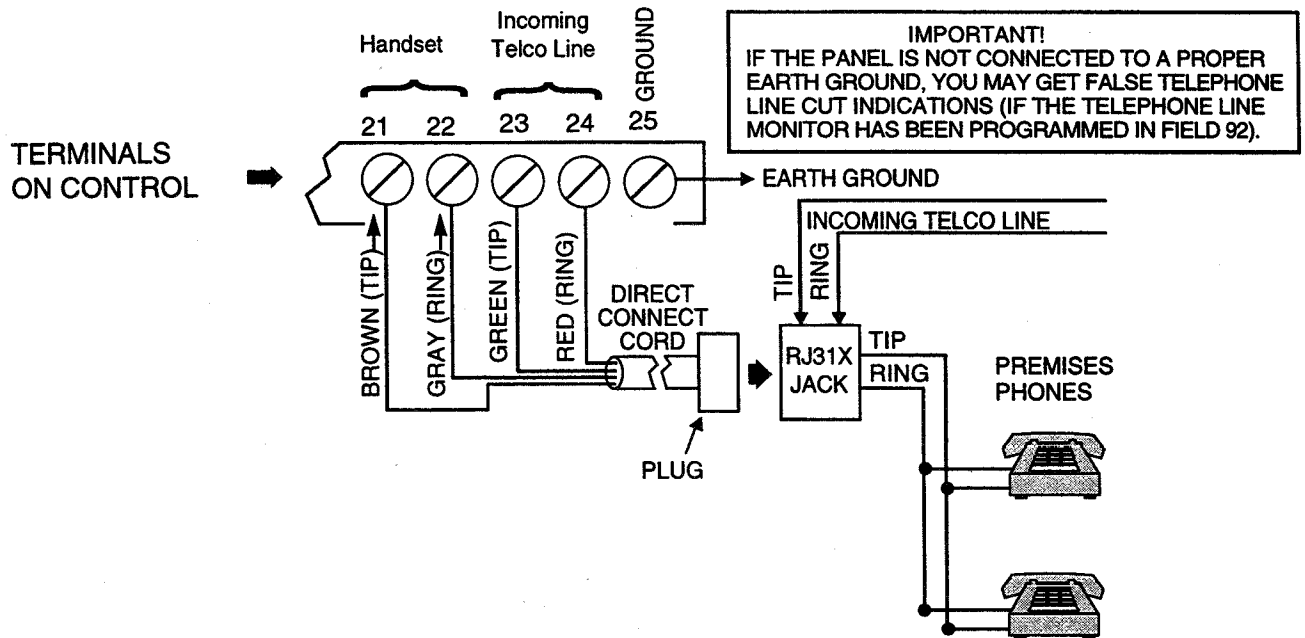

Figure 4. Telephone Line Connections

Wiring The AC Transformer

1321 Wire the 1321 transformer to terminals 1 and 2 on the control board. See wiring table below for wire gauge to use.

Caution must be taken when wiring the transformer to the control panel to guard against blowing the fuse inside the transformer (the fuse is non-replaceable).

4300 If you are going to use a 4300 transformer interface (required if Powerline Carrier devices are going to be used), connect the 4300 transformer's terminals as follows:

- a. Terminals 1, 3 (AC), and 2 (Ground) to control board terminals 1, 2, and 25, respectively (see Figure 5). See table below for wire gauge to use.

WIRING TABLE	
Distance of Transformer From the Control Panel	Wire Gauge To Use
Up to 50 feet	# 20
50-100 feet	# 18
100-250 feet	# 16



Wiring to the AC Transformer must not exceed 250 feet using 16 gauge wire. The voltage reading between terminals 1 and 2 of the control must not fall below 16.5VAC or an "AC LOSS" message will be displayed.

Do not plug the transformer into the AC outlet until you are instructed to do so later in the manual.

- b. Wire the other three terminals (Sync, Data, Com) on the 4300 transformer. Wires from these terminals must be connected to a 9-pin connector on the control board (using a 4142TR cable supplied with the 4300 transformer), as shown in Figure 5. These particular wires can be 24 gauge or larger, and can be run along with the AC and ground wires to the control panel.

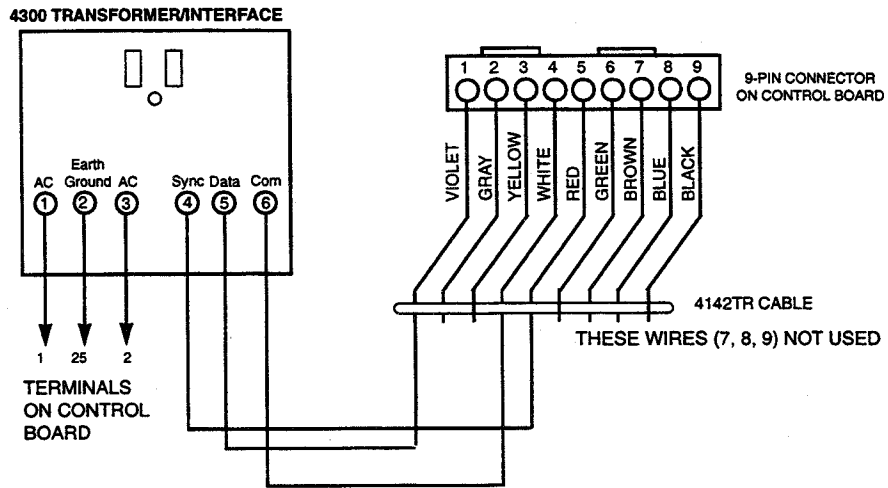

Figure 5. Connections of 4300 Transformer To The Control Board

Installing The Back-Up Battery

If necessary, refer to *FINAL POWER UP* section for information regarding battery size to use, etc.



Do not attach the connector cable to the battery terminals until you are instructed to do so later in the manual.

1. Place the 12-volt back-up battery in the control cabinet.
2. Attach Red and Black wires on the battery connector cable as follows:
 - a. Red to the positive (+) battery terminal **on the control board** (see Summary of Connections Diagram for location, if necessary).
 - b. Black to the negative (-) battery terminal **on the control board**.



Use a 4AH battery or larger for UL installations.

Earth Ground Connections

The designated earth ground terminal (25), must be terminated in a good earth ground for the lightning transient protective devices in this product to be effective. The following are examples of good earth grounds available at most installations:

Metal Cold Water Pipe: Use a non-corrosive metal strap (copper is recommended) firmly secured to the pipe to which the ground lead is electrically connected and secured.

AC Power Outlet Ground: Available from 3-prong, 120VAC, power outlets only. To test the integrity of the ground terminal, use a three-wire circuit tester with neon lamp indicators, such as the UL-Listed Ideal Model 61-035, or equivalent, available at most electrical supply stores.

Section 3. INSTALLING REMOTE KEYPADS

This section lists the wired keypads that may be used and provides instructions for wiring and mounting the keypads.

A preliminary check-out procedure is also provided to ensure that the connected keypads are functioning properly in the system.

Keypads That May Be Used

- Fixed-Word Display: 6128AMT3
- Alpha Display: 6139AMT3
- Up to 8 keypads may be used in the system, independent of auxiliary power considerations (you may need to use an auxiliary power supply if the 600mA aux. output is exceeded)



If you are going to use a 4285 or 4286 Phone Module with this system, you **MUST** use an addressable keypad (6128AMT3 or 6139AMT3) set to the non-addressable mode (address 31).

Wiring To The Keypads

1. Determine wire gauge by referring to the wiring length/gauge chart below.

For devices (Keypads, RF Receivers, Zone Expander, etc.) connected to a single 4-wire run, determine the current drawn by all units connected to the single wire run, then refer to the Wiring Run chart to determine the maximum wire length that can be safely used for each wire size. Current draw for all devices can be found in the SPECIFICATIONS AND ACCESSORIES section.

Note: Refer to "Auxiliary Device Current Draw Worksheet" in the *FINAL POWER UP* section for current draw for all keypads.



Maximum wire lengths for any device that is wired to the control can also be determined from the chart, based on the current draw of that device alone.

Wiring Run Chart For Devices* Drawing Aux Power From The Control (+12V & -12V)					
Wire Size	TOTAL CURRENT DRAWN BY ALL DEVICES CONNECTED TO A SINGLE WIRE RUN				
	50 mA or less	100 mA	300 mA	500 mA	600 mA
#22	500 ft (152m)	250 ft (76m)	80 ft (24m)	50 ft (15m)	42 ft (13m)
#20	750 ft (228.6m)	380 ft (116m)	130 ft (39.6m)	80 ft (24m)	67 ft (20.4m)
#18	1300 ft (396m)	650 ft (198m)	220 ft (67m)	130 ft (39.6m)	115 ft (35m)
#16	1500 ft (457m)	1000 ft (305m)	330 ft (100.5m)	200 ft (70m)	170 ft (52m)

* Includes Keypads, RF Receivers, Zone Expander/Relay Units, or 4285/4286 Phone Module.



The length of all wire runs must not exceed 1500 feet (457m) when unshielded quad conductor cable is used (750 feet if shielded cable is used). This restriction is due to the capacitive effect on the data lines when quad cable or shielded cable is used.

2. Run field wiring from the control to the keypads (using standard 4-conductor twisted wire cable using the wire gauge determined in step 1).

3. Connect remote Keypads to terminals 4, 5, 6, and 7 on the control board, as shown in Figure 6.

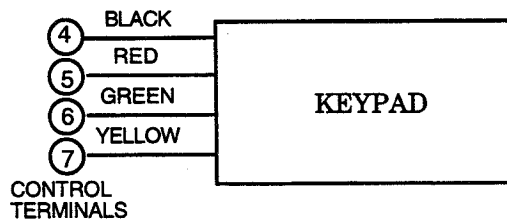

Figure 6. Keypad Connections To The Control Board

Mounting the Keypads

1. Make sure addressable type keypads (6128AMT3 and 6139AMT3) are set to non-addressable mode (address 31), which is the factory default setting. Refer to the instructions provided with the keypad for address setting procedure.
2. Mount the keypads at a height that is convenient for the user. Refer to the instructions provided with the keypad for mounting procedure.
You can either surface mount or flush mount keypads (using an appropriate Trim Ring Kit: 6139TRK). Refer to the mounting instructions and template included with the keypad and/or trim ring kit for specific information.

Using a Supplementary Power Supply to Power Additional Keypads

The control provides 600mA for powering keypads (up to a maximum of 8) and other devices from the auxiliary power output. The backup battery will supply power to these keypads in the event that AC power is lost.

When the control's auxiliary power load for all devices exceeds 600 mA, you can power additional keypads from a regulated, 12VDC power supply (e.g., 487-12 supplies 12V, 250mA; 488-12 supplies 12V, 500mA). Use a UL Listed, battery-backed supply for UL installations.

The 487-12/488-12 power supplies have a backup battery which can power these keypads in the event of AC power loss.



Keypads powered from supplies which do not have a backup battery **will not function** when AC power is lost. Therefore, be sure to power at least one keypad from the Control's auxiliary power output.

Connect the additional keypads as shown in Figure 7, using the keypad wire colors shown. Be sure to observe the current ratings for the power supply used.



Make connections directly to the screw terminals as shown in Figure 7. Make no connection to the keypad blue wire (if present).
Be sure to connect the negative (-) terminal on the Power Supply unit to terminal 4 (AUX -) on the control.

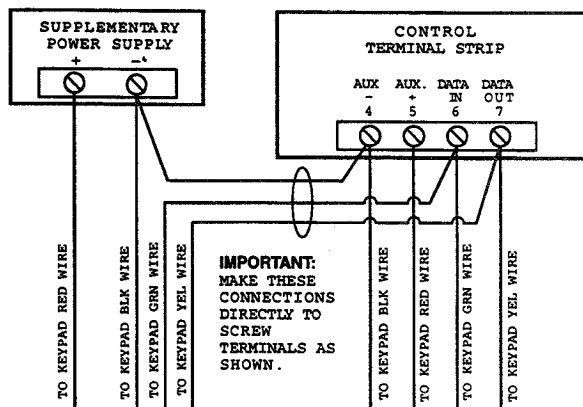

Figure 7. Using A Supplementary Power Supply For Keypads

Preliminary Check-out Procedure

If you want to check that the system is working before connecting field wiring from zones and devices, do the following:

1. Temporarily connect a 2000 ohm end-of-line resistor across each of the basic hard-wire zones 1-8, as shown in the Summary of Connections diagram.

Without actual zone wiring or EOL resistors connected, the keypads of the system will not display the "Ready" message.

2. Power up the system temporarily by plugging the AC transformer (previously wired to the control) into a 120VAC outlet.
3. **Busy - Standby** (Alpha keypads) or **dl** (Fixed-word keypads) will be displayed.

After approximately 1 minute*, the green "READY" LED (or "POWER" LED on some types of keypads) should light, and the words **READY ENTER CODE** (Fixed-word keypads), or ****SYSTEM READY**** (Alpha keypads) should be displayed.

* To bypass the 1-minute delay, press [#] plus 0.

If the **READY ENTER CODE** display does not appear on any of the keypads in the system, or a "Not Ready" message is displayed, check the keypad wiring connections, and make sure each of the 8 basic hard-wired zones has a 2000 ohm resistor connected across its terminals.

4. When you get the proper **READY ENTER CODE** displays on the keypad(s), the system is functioning properly at this point.

Do not remove the EOL resistors until you are ready to make connections to the hard-wired zones, to allow for testing later in the manual.



If an OC or OPEN CIRCUIT is present on the keypad, data from the control is not reaching the keypad. Please check the wiring.

Section 4. BASIC HARD-WIRED ZONES 1-8

This section provides general information for the hard-wired zones in the system, plus specific instructions for installing 2-wire smoke detectors, 4-wire smoke/combustion detectors, and 2-wire latching type glass break detectors.

Installing the Hard-Wired Zones

Common Characteristics for Zones 1-8

- EOLR supervised zones supporting both open circuit and closed circuit devices
- As many 4-wire smoke detectors as can be powered from Aux Power on the control (zones 2-7)
- Programmable for 10, 350, or 700 msec response
- 350 msec (default) should be used for most standard contacts. For vibration type contacts, 10 msec is more suitable

Wiring Burglary and Panic Devices To Zones 1-8

1. Connect sensors/contacts to the hard-wired zone terminals (8 through 20). See the Summary of Connections diagram .
2. Connect closed circuit devices in series in the high (+) side of the loop. The EOLR resistor must be connected in series with the devices, following the last device. See the Summary of Connections diagram.
3. Connect open circuit devices in parallel across the loop. The 2,000 ohm EOLR must be connected across the loop wires **at the last device**.



If the EOLR is not at the end of the loop, the zone will not be properly supervised, and the system may not respond to an open circuit on the zone.

High Resistance Supervision on Hard-Wired Zones 2-8

- Special supervision in the control senses high resistance on hard-wired zone loops 2-8, causing a warning "CHECK" display with the affected zone number to occur when the system is in the disarmed state. The system cannot be armed when this display is present. If the system is in the armed state when the high resistance condition occurs, no display will take place until the system is disarmed.

Wiring 2-Wire Smoke Detectors To Zone 1

1. Connect 2-wire smoke detectors across zone 1 terminals 8 (+) and 9 (-). Observe proper polarity when connecting the detectors.
2. If an EOL resistor is presently connected across zone 1 terminals, remove it. **The EOL resistor must be connected across the loop wires at the last detector.**



In UL installations, only zone 1 may be used as a Fire zone. In addition, an Ademco Model 610-7 must be used as an End-of-Line resistor at the last detector.



The alarm current provided by zone 1 will support only one smoke detector in the alarmed state.

"Verify" Operation of 2-Wire Smoke Detectors in Zone 1

The control panel will "verify" any alarm by resetting the smoke detectors after the first alarm trigger, and then waiting 90 seconds for a second alarm trigger. If the smoke detector or thermostat does not trigger again, the control will disregard the first trigger, and no alarm signal will occur. This feature eliminates false alarms due to electrical or physical transients.

This feature is available only on units that report to the downloader as Rev 4 or higher.

Turning Off Fire Alarm Sounding

You can turn off Fire alarm sounding by pressing the OFF key on any keypad or other arming/disarming device. To clear the "memory of alarm" and to reset the detector's alarm, enter the security code plus OFF again.

COMPATIBLE 2-WIRE SMOKE DETECTORS

Detector Type	System Sensor Model No.
Photoelectric w/heat sensor, direct wire	2300TB
Photoelectric, direct wire	2400
Photoelectric w/heat sensor, direct wire	2400TH
Photoelectric	2451 w/B401B base
Photoelectric w/heat sensor	2451TH w/B401B base
Ionization, direct wire	1400

Detector Type	System Sensor Model No.
Ionization	1451 w/B401B base
Photoelectric duct detector	2451 w/DH400 base
Ionization duct detect	1451DH w/DH400 base
Low-profile, Photoelectric, w/135°F thermal	2100T
Low-profile, Ionization type, direct wire	1100

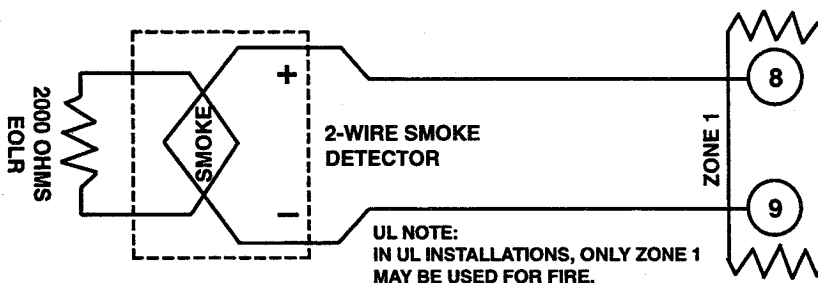



Figure 8. 2-Wire Smoke Detector Connected to Zone 1

Wiring 4-Wire Smoke/Combustion Detectors on Zones 2-7

The system will support as many 4-wire detectors as can be powered from Auxiliary Power on the control, on zones 2-7. Refer to the detector's instructions for complete details regarding its proper installation and operation.

1. Connect 12 volt power for the detectors from Auxiliary Power terminals 4 and 5, (which will interrupt power for fire alarm reset). Observe proper polarity when connecting detectors.
2. Connect detectors (including heat detectors, if used) across terminals of the zone selected (zones 2-7 may be used). All detectors must be wired in parallel.

 Remove 2000 ohm EOL resistor if connected across the selected zone terminals. You must connect the EOL resistor across the loop wires at the last detector.

3. To supervise power, we recommend the use of a System Sensor No. A77-716B supervisory module.

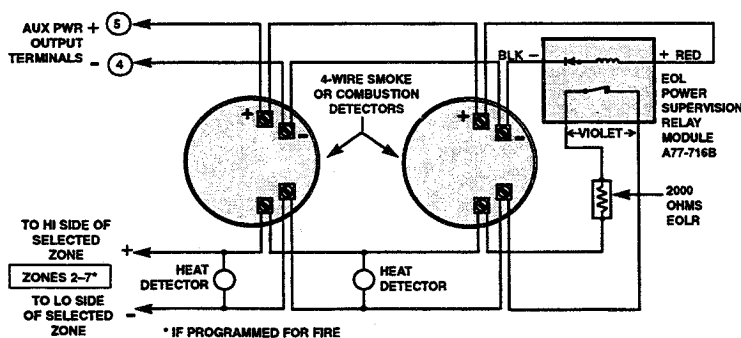

Figure 9. 4-wire Smoke Detector Connections (Zones 2-7)

COMPATIBLE 4-WIRE SMOKE/COMBUSTION DETECTORS	
1412	System Sensor, 4-wire ionization products of combustion detector
2412	System Sensor, 4-wire photoelectric smoke detector
2412TH	System Sensor, 4-wire photoelectric smoke detector w/135° F (57° C) heat detector
A77-716B	System Sensor, EOL relay module (supervisory module for wired 4-wire fire zone).
2112/24T	System Sensor low-profile 4-wire photoelectric smoke detector w/135° F (57° C) heat detector

Wiring 2-Wire Latching Glass Break Detectors On Zone 8

Use zone 8 for connection of compatible 2-wire latching-type glass break detectors.

After an alarm, the first code + OFF turns off the siren and disarms the system; the second code + OFF clears the memory of alarm and resets the glassbreak detector.

1. Connect all detectors in parallel across zone 8 (terminals 19 and 20).

	Remove 2000 ohm EOL resistor if connected across the selected zone terminals. You must connect the EOL resistor across the loop wires at the last detector.
---	---

Compatible Glass Break Detectors

Use detectors that meet the following ratings:

Standby Voltage:	5VDC-13.8VDC
Standby Resistance:	Greater than 20k ohms (equivalent resistance of all detectors in parallel)
Alarm Resistance:	Less than 1.1k ohms (see note below)
Alarm Current:	2 mA-10 mA
Reset Time:	Less than 6 seconds

The IEI 735L series detectors have been tested and found to be compatible with these ratings. You can use up to fifty IEI 735L detectors, connected in parallel.

	You should note that only one detector in the alarmed state can be supported by the alarm current provided by zone 8.
---	---

You can use detectors which exceed 1.1k ohms in alarm, provided they maintain a voltage drop in alarm of less than 3.8 volts.

	Do not use other N.O. or N.C. contacts when using glass break detectors on zone 8. Other contacts may prevent proper glass break detector operation.
---	--

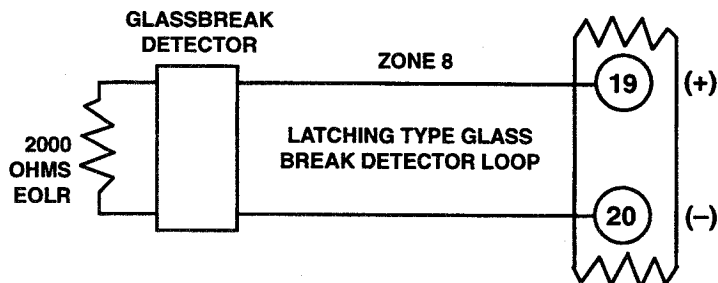

Figure 10. Glass Break Detector Connections To Zone 8

Programming Hard-Wired Zones

Each zone must be programmed into the system using the *56 Zone Programming mode, which assigns characteristics that define the way the system responds to faults on that zone. Refer to the Zone Response Type section and the Zone Programming section for specific instructions on programming hard-wired zones.

Check-Out Procedure For Hard-Wired Zones

After installation and programming of all hard-wired devices is completed, the security system should be checked, as follows.

1. Make certain that all devices and sensors connected to the hard-wired zones are not in a faulted state. Doors and windows with contacts should be closed, PIRs should be covered (use a cloth to mask them temporarily if necessary).
2. Plug in the AC Transformer if you have not already done so.
3. With all hard-wired zones intact, the Alpha keypad connected to the system should display:

****SYSTEM READY****

If the following is displayed,

**NOT READY-Press *
to show faults**

press the [*] key to display the faulted zone(s). Restore any faulted zone(s) as necessary (also make sure that you have connected a 2000 ohm EOL resistor across the terminals of unused zones).

When the **SYSTEM READY** message is displayed, you can proceed to the next step.

4. Fault and then restore every contact or sensor on each zone individually to ensure that it is being monitored by the system. Each time a zone is faulted, the keypad should display the number of the faulted zone. When each zone is restored, the **SYSTEM READY** message should appear again.
You will need to observe the keypad as each zone is faulted and restored.
5. When you get the proper displays on the keypad(s), the hard-wired zones in the system are functioning properly.

Section 5. WIRED ZONE EXPANSION

This section provides information regarding the use of expansion modules for expanding the number of wired zones in the system, the modules that can be used and their wiring connections.

Installing Zone Expansion Units

You can add an additional 8 wired EOLR zones to the basic control's 8 zones, for a total of 16 wired zones, by using a No. 4219 Wired Expansion Unit, or 4229 Wired Expansion/Relay Unit.

- Location**
- You can mount an expansion unit within the control cabinet if space permits. Otherwise, mount the unit outside the cabinet.
- Supervision**
- Units are supervised against removal. Keypads will display **CHECK** and zone 09 if a zone expander is disconnected.
 - Units have tamper protection for security when mounted outside of the cabinet.
- Zone Information**
- Assign zone numbers 10–17 for the eight wired expansion loops (designated A to H). You can program these zones individually (in *56 interactive mode). Expansion zones must also be programmed as input type 2 (AW) when prompted.

Connections and Set-Up

- Connect the 4219 or 4229 module to the control's keypad terminals (see diagram below).
- Set the 4219 or 4229's DIP switch for device address "1" (switch 2 "OFF" and switches 3, 4, 5 "ON"). Switch 1 determines expansion zone A's response time ("ON" = normal response, "OFF" = fast response). For location of the DIP switch in the unit, see the diagram below (location of DIP switch for both units is in the same location).

For additional information, see instructions supplied with the 4219 and 4229.

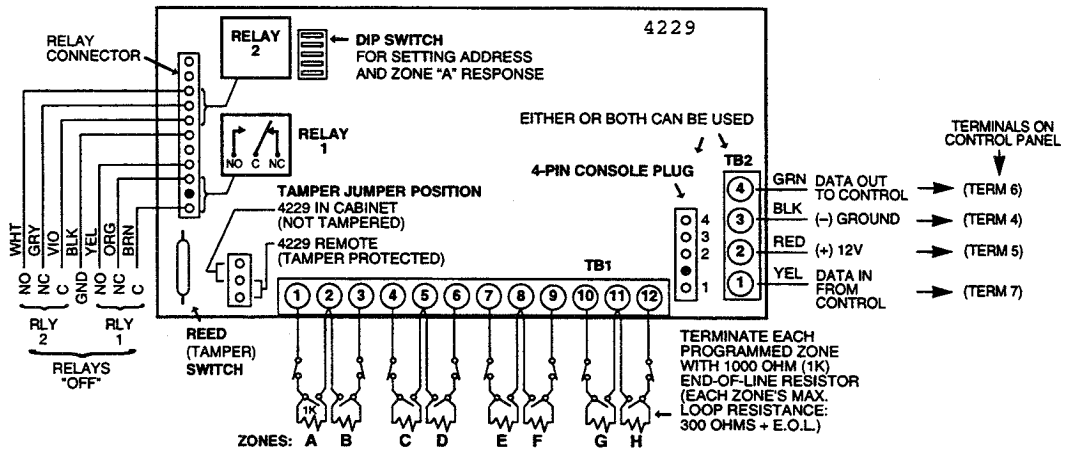
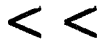
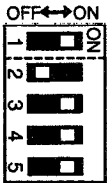

Figure 11. Wiring Connections, 4219 & 4229 (4229 shown)

Programming Wired Expansion Zones

Each zone must be programmed into the system using the *56 Zone Programming mode, which assigns characteristics that define the way the system responds to faults on that zone. Refer to the Zone Response Type section and the Zone Programming section for specific instructions on programming wired expansion zones.

Check-Out Procedure For Wired Expansion Zones



Whenever it becomes necessary to disconnect power in order to add a module or keypad, always disconnect the battery and then the AC transformer in that order. After installation has been completed, connect the AC transformer first followed by connection of the battery.

After you have completed installation and programming of all devices, all expansion zones in the security system should be checked as follows:

1. Make certain that all devices and sensors connected to the wired expansion zones are not in a faulted state. Doors and windows with contacts should be closed, PIRs should be covered (use a cloth to mask them temporarily if necessary).
2. With all zones intact (including hard-wired zones), the Alpha keypad connected to the system should display :

****SYSTEM READY****

If the following is displayed,

**NOT READY-Press *
to show faults**

press the [*] key to display the faulted zone(s). Restore any faulted zone(s) as necessary (also make sure that you have connected a 1000 ohm EOL resistor across the terminals of unused expansion zones on the 4219 or 4229 module).

When the ****SYSTEM READY**** message is displayed, you can proceed to the next step.

3. Fault and restore every contact or sensor in each expansion zone individually to ensure that it is being monitored by the system. Each time a zone is faulted, the keypad should display the number of the faulted zone. When each zone is restored, the ****SYSTEM READY**** message should appear again.

You will need to observe the keypad in each zone as each zone is faulted and restored.

4. When you get the proper displays on the keypad(s), the wired expansion zones in the system are functioning properly.



If a "CHECK 09" message appears on the display, data from the control is not reaching the zone expander module. Check the wiring and DIP switch settings.

Section 6. WIRELESS EXPANSION (5800 SYSTEM)

This section provides instructions for installing 5800 series wireless receivers and transmitters.

General Information

In addition to its basic wired zones, the control supports up to 30 wireless zones using an appropriate 5881 (5882 in Canada) type RF receiver. The actual number of zones supported depends on whether you are using a wired zone expander module.

For example: If you are using only four of the wired expansion loops, a 5881H (5882H in Canada) RF Receiver could add 26 RF zones to the system, using any unused zone numbers 10–31, for a combined total of 30 wired and wireless expansion zones.

The receiver can detect signals from wireless transmitters within a nominal range of 200 feet.

RF Receiver	No. of Zones
5881L/5882L	up to 8
5881M/5882M	up to 16
5881H/5882H	up to 30

Receiver Supervision

The receiver is supervised, and a trouble report will be generated. **CHECK** and zone 09 will also be displayed.

- a) If communication between the panel and the receiver is interrupted.
- or**
- b) If no valid RF signals from at least one supervised wireless transmitter are received within 12 hours.

House Identification

If you are using a 5804BD, 5827 or 5827BD Wireless Keypad with the system, you must program a House ID Code (01–31) in field *24 to establish proper communication, and the keypad must be set to the same ID.

House ID 00 disables all wireless keypads.

Installing the 5881/5882 Receiver

RF System Installation Advisories

Disregard the following advisories if the receiver is mounted in the control cabinet.

1. Place the RF Receiver in a high, centrally located area for best reception.
2. Do not locate the receiver or transmitters on or near metal objects. This will decrease range and/or block transmissions.
3. Do not locate the receiver in an area of high RF interference (revealed by frequent or prolonged lighting of the LED in the receiver. . .random flicker is OK).
4. The RF receiver must be at least 10 feet from any remote keypads to avoid interference from the microprocessors in those units.

Installation and Setup of the 5881/5882 Receiver

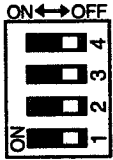

1. Set the receiver's DIP switch for device address "0", as described in its instructions (all switches to the right. . . "off").
2. Mount the receiver. The RF receiver can detect signals from transmitters within a nominal range of 200 feet. Take this into consideration when determining mounting location.
3. Connect the receiver's wire harness to the control's keypad terminals (4, 5, 6, and 7). Plug the connector at the other end of the harness into the receiver.
4. Refer to the installation instructions provided with the receiver for further installation procedures regarding antenna mounting, etc.

NOTE: CIRCUIT BOARD IS MOUNTED IN CONTROL'S CABINET, GROUNDING LUGS (2) PROVIDED **MUST** BE INSERTED IN LEFT-HAND TERMINALS OF ANTENNA BLOCKS AND SECURED TO CABINET (SEE RECEIVER'S AND CONTROL'S INSTRUCTIONS)

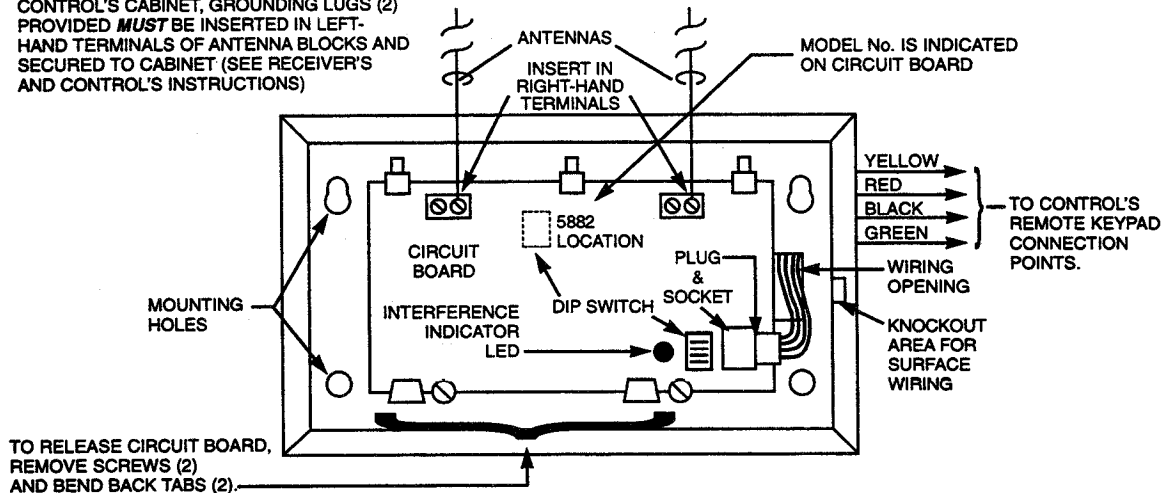

Figure 12. 5881/5882 RF Receiver (cover removed)

Installing the 5800TM Module

Installation of this module is necessary only if you are using one or more 5827BD Wireless Bi-directional keypads or 5804BD transmitters.

Mounting the 5800TM Module

The 5800TM must be located next to the RF receiver (between one and two feet from the receiver's antennas). The 5800TM must not be installed within the control cabinet. Mount the unit using its accompanying mounting bracket.

5800TM Wiring Connections

Connect the 5800TM to the control panel's keypad connection terminals, using the supplied connector with flying leads, as follows:

Wire	Terminal On Control
BLACK (Ground):	Terminal 4
RED (+12VDC)	Terminal 5
GREEN (Data to Control)	Terminal 6
YELLOW (Data from Control)	Terminal 7
BLUE: Not Used	

Do not cut any of the jumpers on the 5800TM when using it with the Vista-20AMT3.

For additional information, refer to the 5800TM's instructions.

5800 Series Transmitters

General

5800 series transmitters have built-in serial numbers that must be "enrolled" by the system using the *56 or *83 interactive mode, or input to the control via the downloader. 5800 series transmitters (except 5827 described separately) do not have DIP switches.

Each transmitter's zone number is programmed into the system in *56 mode. Some transmitters, such as the 5816 and 5817, can support more than one "zone" (referred to as loops or inputs). On the 5816 for example, the wire connection terminal block is loop 1, the reed contact is loop 2. Each loop must be assigned a different zone number.

UL

The 5816 and 5817 transmitters do not have EOL supervision of their loop wiring. Therefore, for UL Household Burglary installations, the loop wiring may not exceed 3 feet.

For button transmitters (RF "keys"), such as the 5801, 5804, and 5804BD, you must assign a unique zone number to each individual button used on the transmitter. Each button on the transmitter also has a pre-designated loop or input number, which is automatically displayed.

Programming an RF House ID (01-31) in field *24 is **necessary only if using 5827 or 5827BD wireless keypads or 5804BD transmitters**. An RF House ID is not necessary for other 5800 series transmitters and the entry should be left at "00" (default) in those cases.

The 5827 reports low battery status as zone "00."

Transmitter Supervision

Except for some transmitters that may be carried off-premises (5802, 5802CP, 5804, 5804BD, 5803, and 5827, and 5827BD), each transmitter is supervised by a check-in signal that is sent to the receiver at 70-90 minute intervals. If at least one check-in is not received from each supervised transmitter within a 12-hour period, the "missing" transmitter number(s) and "CHECK" will be displayed.

The supervision for a particular transmitter in the system that may also be carried off the premises (5801, 5802MN) may be turned off by enrolling it as a "UR" (unsupervised RF) type, as described later.

5800 series transmitters have built-in tamper protection and will annunciate as a "CHECK" condition if covers are removed.

Transmitter Input Types

All of the transmitters described have one or more unique factory assigned input (loop) ID codes. Each of the inputs requires its own programming zone (e.g., a 5804's four inputs require four programming zones). See APPENDIX A toward the end of this manual.

Transmitters can be enrolled as one of the following types:

Type	Description
"RF" (Supervised RF)	Sends periodic check-in signals, as well as fault, restore, and low battery signals. The transmitter must remain within the receiver's range.
"UR" (Unsupervised RF)	Sends all the signals that the "RF" Type does, but the control does not supervise the check-in signals. The transmitter may therefore be carried off-premises.
"BR" (Unsupervised Button RF)	These only send fault signals. They do not send low battery signals until they are activated. The transmitter may be carried off-premises.

Transmitter Battery Life



Do not install batteries in wireless transmitters until ready to enroll, as will be indicated in the procedure that follows under "Programming the Receiver and Transmitters." After enrolling, batteries need not be removed.

- Batteries in the wireless transmitters may last from 4–7 years, depending on the environment, usage, and the specific wireless device being used. Factors such as humidity, high or low temperatures, as well as large swings in temperature may all reduce the actual battery life in a given installation. The wireless system can identify a true low battery situation, thus allowing the dealer or user of the system time to arrange a change of battery and maintain protection for that given point within the system.
- Some transmitters (e.g., 5802, 5802CP, and 5804) contain long-life but non-replaceable batteries, and no battery installation is required. At the end of their life, the complete unit must be replaced (and a new serial number enrolled by the control).
- Button type transmitters (ex. 5801, 5802, 5802CP & 5804) should be periodically tested for battery life.
- The 5802MN and 5804 button transmitters have replaceable batteries.

Using The Transmitter Sniffer Mode

1. Enter your Installer code + # + 3 from keypad. This initiates a procedure that will provide a check that all transmitters have been properly programmed.
2. The keypad will display all zone numbers of wireless units programmed into the system. Fault each transmitter in turn, causing each one to send a signal, **rather than let each transmitter send an automatic supervisory signal.**

As the system receives a signal from each of the transmitters, the zone number of that transmitter will **disappear** from the display. The transmitters may be checked upon installation, or in an installed system.

3. When all transmitters have been checked, exit the sniffer mode by keying **Installer code + OFF.**

NOTE: Sniffer mode does not automatically expire. You must manually exit (installer code + OFF) sniffer mode to return to normal operation. Sniffer Mode also terminates if a user arms the system.

5800 Series Transmitters Table

Also refer to APPENDIX A near end of this manual for transmitter input loops/button locations.

Model	Description	Input Type And Special Notes
5801	Wireless Panic Transmitter	<ul style="list-style-type: none"> • Unit has 4 pushbuttons, each with a unique Input (loop) code. • Each pushbutton must be assigned to a zone. Enroll as "3" for RF (supervised), or "4" for UR (unsupervised). Note: Input loop (button) No. 4 must always be used.
5802 5802CP	Pendant Belt Clip (Personal Emergency) Transmitters	Enroll as "5" for BR (single pushbutton type transmitter).
5802MN	Miniature Personal Emergency Trans.	Enroll as "3" for RF (supervised), or "4" for UR (unsupervised). Single pushbutton type transmitter.
5804	Wireless Key Transmitter	<ul style="list-style-type: none"> • Has 4 pushbuttons, each with a unique input (loop) code. • Each pushbutton must be assigned to a zone. Enroll as "5" for BR (button type transmitter). Note: All buttons must be assigned the same Input Type.
5806 5807 5808	Wireless Photoelectric	Enroll as "3" for RF (supervised). At the "INPUT S/N" prompt, fault the detector as follows: <ol style="list-style-type: none"> On many detectors, press the special test switch (not test button) provided for faulting the detector (see detector's instructions) then release. Note: With some detectors, two contacts must be shorted to fault the detector. Disengage detector's cover and swing cover open – these contacts are on the PC board near a blue jumper (see detector's instructions). Momentarily short these contacts with a small screwdriver. Two keypad beeps will occur when the detector is faulted the first time. Wait 6–8 seconds, then press and release the test switch (or momentarily short the contacts) again. 3 beeps will occur if the control has accepted the input code, and a summary display showing the enrolled input (loop) No. will appear.
5816	Door/Window Transmitter	Has two unique input (loop) zones: one for a wired closed circuit contact loop, and the other for a built-in reed switch (used in conjunction with a magnet). Either or both may be used. Enroll as "3" for RF (supervised).
5817	Multi-Point Universal Transmitter	<ul style="list-style-type: none"> • Has three unique input (loop) codes: one for a DIP switch set "Primary" contact loop, and the others for two "Auxiliary" closed circuit contact loops. • The "Primary" loop may be set for: <ol style="list-style-type: none"> Repeating or Single Transmission, Normally Open or Normally Closed Circuit Slow or Fast Response 3-Minute or No Transmission Inhibit. DIP Switches: Set all DIP switches to the OFF position when enrolling the serial number. Enroll as "3" for RF (supervised). Note: All loops must be assigned the same Input Type.
5818	Recessed Magnetic Contact Transmitter	Enroll as "3" for RF (supervised).
5819	Shock Processor Transmitter	Has three unique input (loop) zones: one for a wired closed circuit contact loop, one for use with inertia type shock detectors (mounted externally), and one for a built-in reed switch (used in conjunction with a magnet). Enroll as "3" for RF (supervised).
5849	Glassbreak Detector/Transmitter	Enroll as "3" for RF (supervised).
5890	PIR Detector/Transmitter	Enroll as "3" for RF (supervised). The cover must be on the unit when enrolling the serial number.

† When "enrolling" a transmitter's ID code(s), any PIR that may be in the vicinity (and is not being enrolled) should be covered with a cloth, tissue, etc., to prevent activation of that PIR.

Installing 5800 Series Transmitters

To be sure reception of the transmitter's signal at the proposed mounting location is adequate, perform a Go/No Go test.

Go/No Go Test Mode

The Go/No Go tests will verify adequate RF signal strength from the proposed transmitter location, and allow you to reorient or relocate transmitters if necessary, before mounting the transmitters permanently.

This mode is similar to the transmitter test mode, except that the wireless receiver gain is reduced. This will enable you to make sure that the RF signal from each transmitter is received with sufficient signal amplitude when the system is in the normal operating mode.

1. With at least one 2-line Alpha keypad (6139AMT3) connected to the system enter installer code + [#] + 4 from keypad.
2. Once you have placed transmitters in their desired locations and the approximate length of wire to be run to sensors is connected to the transmitter's screw terminals (if used), fault each transmitter. Do not conduct this test with your hand wrapped around the transmitter as this will cause inaccurate results.

Note: On button type transmitters whose buttons have been set to Arm Away, Arm Stay, or Disarm, pressing a button will take the system out of the Go/No Go Test mode and cause that action.

 - a. The keypad will beep three times to indicate signal reception and display the appropriate zone number.
 - b. If the keypad does not beep, reorient or move the transmitter to another location. Usually a few inches in either direction is all that is required.
3. If each transmitter produces the proper keypad response when it is faulted, you can then permanently mount each of the transmitters according to the instructions provided with them.
4. Exit the Go/No Go test mode by entering: **Installer code + OFF.**

Setting DIP switches on the 5827 Transmitter(s)

A 5827 transmitter must be set to the programmed House ID, using its DIP switches.

5827 Wireless Keypad DIP Switch Table

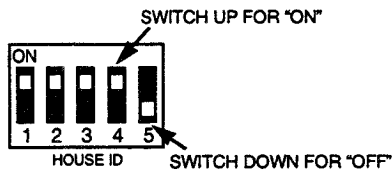

SHOWN SET FOR HOUSE ID# 30

HOUSE ID	DIP SWITCH POSITION				
	1	2	3	4	5
1	-	-	-	-	UP
2	-	-	-	UP	-
3	-	-	-	UP	UP
4	-	-	UP	-	-
5	-	-	UP	-	UP
6	-	-	UP	UP	-
7	-	-	UP	UP	UP
8	-	UP	-	-	-
9	-	UP	-	-	UP
10	-	UP	-	UP	-
11	-	UP	-	UP	UP
12	-	UP	UP	-	-
13	-	UP	UP	-	UP
14	-	UP	UP	UP	-
15	-	UP	UP	UP	UP
16	UP	-	-	-	-

HOUSE ID	DIP SWITCH POSITION				
	1	2	3	4	5
17	UP	-	-	-	UP
18	UP	-	-	UP	-
19	UP	-	-	UP	UP
20	UP	-	UP	-	-
21	UP	-	UP	-	UP
22	UP	-	UP	UP	-
23	UP	-	UP	UP	UP
24	UP	UP	-	-	-
25	UP	UP	-	-	UP
26	UP	UP	-	UP	-
27	UP	UP	-	UP	UP
28	UP	UP	UP	-	-
29	UP	UP	UP	-	UP
30	UP	UP	UP	UP	-
31	UP	UP	UP	UP	UP

Section 7.

RELAY OUTPUTS & POWERLINE CARRIER DEVICES

Relay/Powerline Carrier Device Basics

Relays and Powerline Carrier devices (ex. X-10 brand devices) are programmable switches that can be used to perform many different functions. They can be used to turn lights on and off, control sounders, or for status indications. In this system, each device must be programmed as to how to act (ACTION), when to activate (START), and when to deactivate (STOP). Each of these is described, and in the programming procedure for *80 and *81 interactive modes that are provided in the programming sections of this manual.

The control supports a total of 8 output devices in the following configurations:

- One 4204 relay module (4 relays) and 4 Powerline Carrier devices.
- One 4229 zone/relay module (2 relays) and 6 Powerline Carrier devices.
- Up to 8 Powerline Carrier devices (8 minus the number of output relays used).



A 4204 cannot be used if a 4219 or 4229 is already being used and vice-versa.

The 4204 and 4229 modules provide Form C (normally open and normally closed) contacts. Powerline Carrier devices are controlled by signals sent through the electrical wiring at the premises via a 4300 transformer. Therefore, if using Powerline Carrier Devices, a 4300 transformer must be used in place of the regular system transformer.



Once a device is programmed into the system, the user sees no difference between a Powerline Carrier device or a relay output device.

In *80 and *81 interactive modes, a series of keypad prompts will request entries for programming of the Relay outputs and/or Powerline Carrier devices used in the system. Refer also to "OUTPUT RELAYS/POWERLINE CARRIER DEVICES WORKSHEET FOR *80 AND *81 INTERACTIVE MODES" in the blank programming form.

4204 and 4229 Relay Modules

4204/4229 Setup

The 4204 or 4229 unit can be mounted either remotely or in the control panel. The following steps should be taken to properly set up the 4204 or 4229:

1. Connect the 4204/4229 to the control's remote keypad terminals (4-7), using the connector supplied with the 4204 and 4229. Use standard 4-conductor twisted cable for long wiring runs.
2. Set the 4204/4229's DIP switch for a device address of "1" (switch 2 "OFF" and switches 3, 4, 5 "ON"). Switch 1 determines the unit's cover tamper response ("ON" = disabled, "OFF" = enabled).
3. Connect the desired field wiring to the unit's relay contact terminals.

Supervision

- 4204 and 4229 modules are supervised against removal. **CHECK** and zone 09 will be displayed if a module is disconnected from the control's terminals (4, 5, 6, & 7).

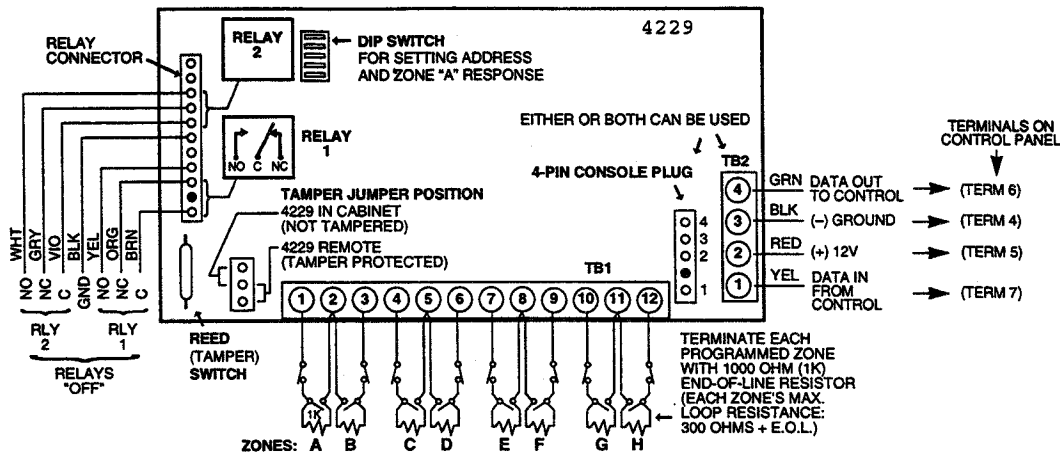

Figure 13. 4229 Connections to Control

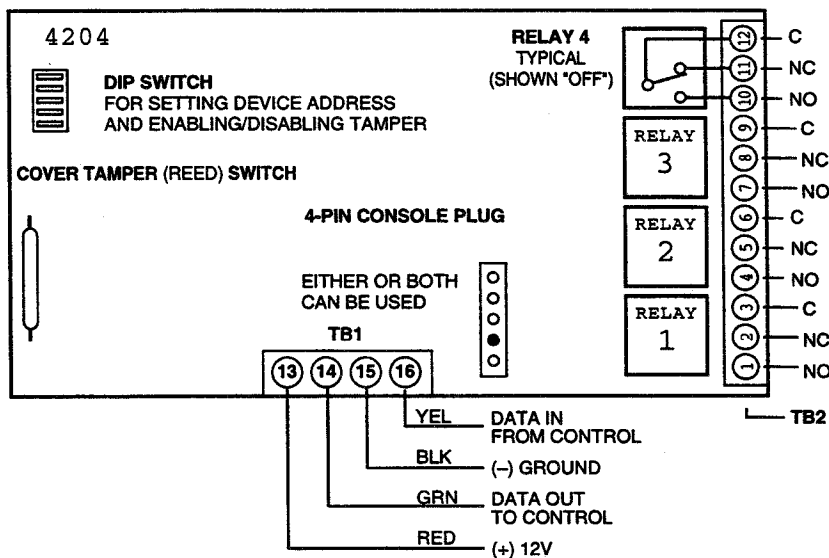

Figure 14. 4204 Connections to Control

Powerline Carrier devices

UL Powerline Carrier devices and the 4300 transformer are not listed for fire or burglary functions and are intended for home automation.

 When using Powerline Carrier devices, you must use a 4300 transformer **instead** of the 1321 transformer.

The 4300 transformer provides AC power to the control panel, and also supplies signals from the control panel through the premises AC wiring to the Powerline Carrier devices (which are plugged into AC outlets). Devices plugged into Powerline Carrier devices can then be made to perform various functions in response to commands entered at the keypads in the security system.

Wiring Connections

1. Splice one end of a 3-conductor cable to the wire ends of the 4142TR cable supplied with the 4300 transformer.
2. Connect the 4142TR cable plug to the 9-pin connector on the control (see SUMMARY OF CONNECTIONS diagram for location of the 9-pin connector).
3. Connect the other end of the 3-conductor cable to the 4300 transformer, as indicated in the table below and in the diagram that follows.

4300 TRANSFORMER WIRE CONNECTIONS

4300 Terminal	To Terminal On Control
1 (AC)	1 (16.5VAC in)
2 (Ground)	25 Earth Ground terminal
3 (AC)	2 (16.5VAC in)

4300 Terminal	4142TR Cable Wire
4 (Sync)	RED (Pin 5 of 9-pin connector)
5 (Data)	VIOLET (Pin 1 of 9-pin connector)
6 (Com)	WHITE (Pin 4 of 9-pin connector)

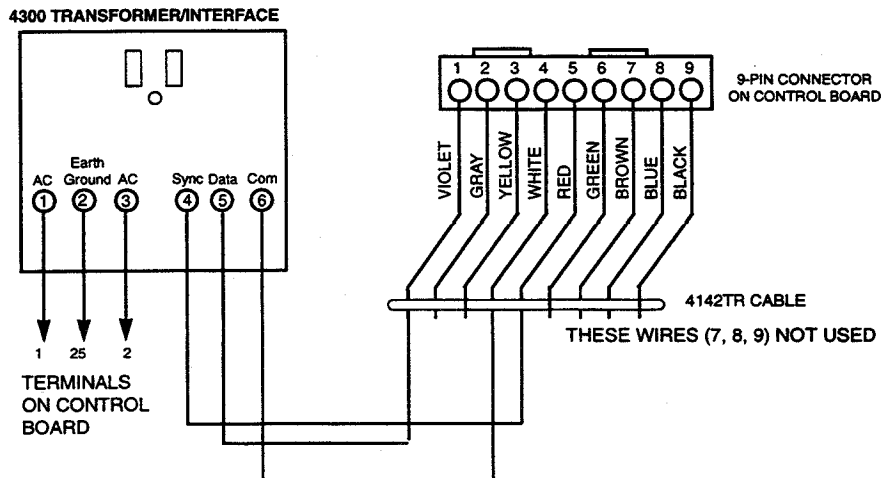

Figure 15. 4300 Transformer Wiring Connections

Programming Relay Outputs

In this system, each device must be programmed as to how to act (ACTION), when to activate (START), and when to deactivate (STOP). Refer to the programming procedures for *80 and *81 interactive modes that are provided in the programming sections of this manual for specific programming details.

Section 8. 4285 & 4286VIP PHONE MODULES

This section provides instructions for mounting and wiring the 4285 or 4286 Phone Modules.

Installing the Phone Module

General Information

The 4285 or 4286VIP Phone Modules are add-on accessories for the VISTA-20AMT3 that permits access to the security system via a Touch-tone phone (either on premises or by a call-in when away). The 4286VIP phone module has the additional capability of controlling thermostat(s) and providing external speaker output.

The Phone Module can announce many of the same words that would normally be displayed on an Alpha keypad under the same system conditions.



- Only one Phone Module can be used in this security system.
- When using the 4285 or 4286 Phone Module, addressable keypads must be used in the system, but set to the non-addressable mode (address 31),

When properly connected, the 4285/4286 Phone Module will enable the user to do the following via a Touch-tone telephone:

- a. Receive synthesized voice messages over the phone regarding the status of the security system.
- b. Arm and disarm the security system and perform most other commands using the telephone keypad, with voice annunciation being provided over the phone as confirmation after any command is entered.

The phone used for phone access must have Touch-tone capability, though Touch-tone service is not necessary (if premises uses PULSE dialing, switchable phones must be set for Touch-tone temporarily before attempting phone access).

A *Phone Access User's Guide* for phone access to the security system is provided with the Phone Module for the user of the system.

Mounting the 4285 or 4286 Phone Module

The Phone Module may be mounted in the control cabinet if space is available or, if this is not possible, on the side of the cabinet or adjacent to it.

When mounting the Module outside the cabinet, use the screw holes at its rear which will permit it to be mounted horizontally or vertically (2-faced adhesive tape may be used, if preferred). Wires can be brought out from the side or back (a round breakout is also available on the back).

Affix the Phone Module's connections label (supplied separately) to the inside of the Phone Module's cover if the cover is used. If you have installed the module within the cabinet, affix the label to the inside of the control cabinet's door.



If you are also using an Audio Alarm Verification (AAV) unit, refer to the AUDIO ALARM VERIFICATION (AAV) UNIT section for the wiring connections required when using both a Phone Module and an AAV unit. If you are not using an AAV unit, follow the wiring connections indicated in this section for the Phone Module.

Phone Module Wiring

The 4285 or 4286 phone module is wired between the control panel and the premises handset(s). It listens for touch tones on the phone line and reports them to the control panel. During on-premises phone access, it powers the premises phones; during off-premises phone access, it seizes the line from the premises phones and any answering machines.

Note: The phone lines must be in service for the phone module to function, even when accessing the system from an on-premises phone.

1. Make 12V (+) and (-) and data in and data out connections from the Phone Module to the control, using the connector cable supplied with the Phone Module (see Figure 16).

Color Lead	Terminal On Control
GREEN	DATA IN (terminal 6)
BLACK	AUX - (terminal 4)
RED	AUX + (terminal 5)
YELLOW	DATA OUT (terminal 7)

2. Insert the keyed connector at the other end of the connector cable into the mating header on the Phone Module (see diagram on next page for location of the header).
3. Connect terminals 1 through 5 on either Phone Module as shown in the Wiring Table below and in the 4285/4286 wiring diagram that follows.



Use an RJ31X jack with a direct-connect cord and make all connections exactly as shown. If the leads on the direct-connect cord are too short to reach their assigned terminals, splice additional wires to them, as required.

4285/4286 WIRING TABLE

4285/4286 Terminal	Connects to:
1. Phone In (Tip)	Terminal (21) on control.
2. Phone In (Ring)	Terminal (22) on control.
3. Phone Out (Tip)	BROWN lead from direct-connect cord.
4. Phone Out (Ring)	GRAY lead from direct-connect cord.
5. Ground	Earth ground terminal (25) on control.
6. Output High	Not used (4285). Spkr Hi on 4286.
7. Output Rtn	Not used (4285). Spkr Lo on 4286.



If no touch tones are produced following access to the security system **from on-premises** (this problem may arise in rare cases), it may be necessary to reverse the wires connected to terminals 3 and 4 on the Phone Module **and** the wires connected to terminals (21) & (22) on the control. The wiring diagram shows the wiring connections that will provide proper operation in most cases.

Caller ID Units

If the telephone system on the premises includes a Caller ID unit, connect the unit **directly to the "Handset" terminals (21 & 22) on the control**, as shown in 4285/4286 Phone Module Wiring Connections diagram that follows.

4285/4286 WIRING NOTES:

1. Wire either Phone Module exactly as shown, using a direct-connect cord and RJ31X jack.
2. If Touch-tones are not heard when pressing keys following phone access to the security system via an on-premises phone, try reversing the pair of wires connected to terminals 3 & 4 on either phone module **and** the pair of wires connected to terminals 21 & 22 on the control.
3. If an error signal (fast busy signal) is heard when trying to access the system via the phone, check for correct line seizure wiring, as described in note 4.
4. Connection to the incoming Telco line via a RJ31X jack and direct-connect cord, as shown in this diagram, is essential, even if the system is not connected to a central station. **The 4285 or 4286 phone module will not function if this is not done.**

The house phone lines (gray and brown wires) must be wired to the Phone Module terminals, not to the control terminals. Otherwise, an error signal (fast busy signal) will occur when trying to access the system from an on-premises phone.

5. If the telephone system on the premises includes a Caller ID unit, connect the unit **directly** to the "Handset" terminals (21 & 22) on the control, as shown.

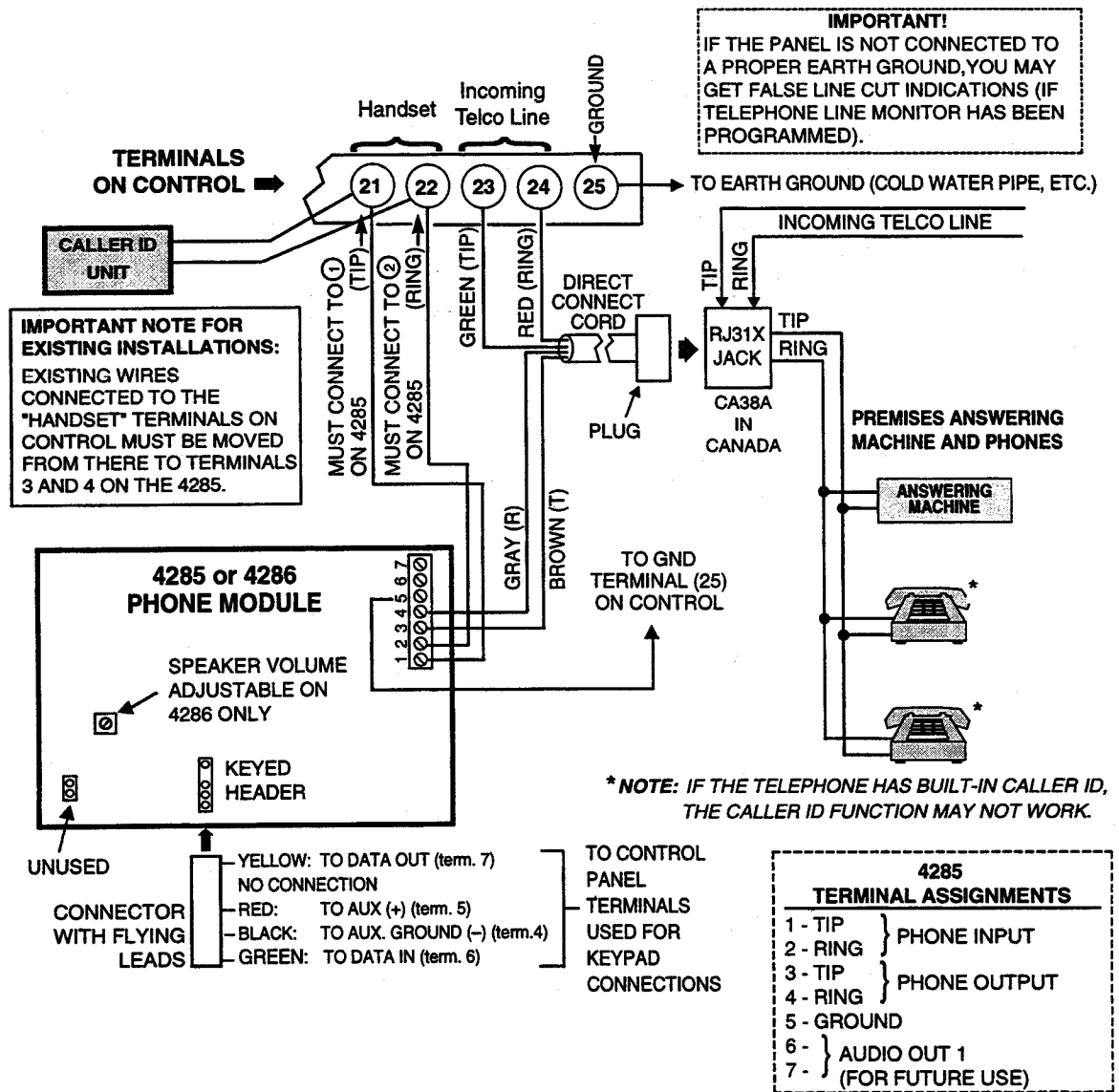

Figure 16. 4285 /4286 Phone Module Wiring Connections

Programming the 4285 Phone Module

The system must be programmed for use with the 4285 or 4286VIP Phone Module, including assigning a phone code and selecting words from the alpha vocabulary. Refer to the Programming sections for specific programming details.

Checking the Operation of the 4285/4286 Phone Module

To Check Phone Module Operation From an On-Premises Phone:

1. Pick up phone and enter the programmed 2-digit phone code. Annunciation of a system status report should automatically start. See the User's Guide accompanying the Phone Module for detailed information regarding the nature of the status report, if necessary.
2. During any pause in the status report, or immediately following it, key the following via the keypad on the phone:
Installer Code, then press key 1 (OFF).
3. A "beep" should be heard on the phone and from a wired keypad, and the words **SYSTEM READY** or **NOT READY-Press * to show faults*** should be heard, indicating that the command was entered successfully.
* **NOT READY-Press * to show faults** would indicate an open zone.
4. Hang up the phone.

To Check Phone Module Operation From an Off-Premises Phone:

1. Have someone dial the premises phone number, using a TouchTone phone.
 - If the phone system does not include an answering machine, 2 long tones will be heard in the caller's phone, followed by a voice prompt "HELLO, ENTER PHONE CODE NOW." The caller should enter the programmed 2-digit phone code.
 - If the premises phone system includes an answering machine, the 2-digit phone code should be entered during a pause at the beginning of, or during, the outgoing answering machine message.
2. When the 2-digit phone code is entered, the caller will hear a voice prompt asking for entry of the 4-digit system code ("**ENTER SYSTEM CODE NOW**").
3. The caller should then enter the installer code or any valid user code. As a safety feature, there is a 3-try limit in which to enter each code (phone code and system code), after which time the call-in will be aborted. Also, if no keys are pressed for a period of 20 seconds, the call-in will be aborted.
4. Annunciation of a system status report will start if both codes were entered correctly.
5. During any pause in the status report, or immediately following it, the caller should key the following via the keypad on the phone:
Installer Code, then 1 (OFF).
6. A "beep" should be heard (and from a wired keypad on the premises), and the words **SYSTEM READY** or **NOT READY-Press * to show faults*** should be heard on the caller's phone, indicating that the command was entered successfully.
* **NOT READY-Press * to show faults** would indicate an open zone.
7. At this point, the caller can hang up the phone.
8. Verify with the caller that there was successful access to the system and that the appropriate annunciations were heard over the phone.

Section 9. EXTERNAL SOUNDERS

This section provides a list of compatible sounders and connection information for an external sounder.

Compatible Sounders

Ademco AB-12M 10" Motorized Bell & Box	Motor bell & box. UL Grade A. 100 mA current draw.
Ademco 1011BE12M 10" Motorized Bell & Box	Motor bell & box. UL Listed. 100 mA current draw.
Ademco 702 Outdoor Siren	Self-contained 6–12 volt siren (driver built-in) and weather proof for outdoor use. Can be wired for either a steady or warble sound.
Ademco 719 2-Channel Siren	Two-channel, self-contained 6–12-volt siren (driver built in). 109dB @ 10 feet. 550mA current draw.
Ademco 747 Indoor Siren	Self-contained 12 volt siren (driver built-in) for indoor wall mount. 747F available for flush mounting.
Ademco 747UL Indoor Siren	Self-contained siren (driver built-in) for indoor wall mount. UL Listed.
Ademco 744 Siren Driver	6 jumper-selected sound outputs. Rated at 119dB with use of an 8-ohm 30 watt speaker.
Ademco 745X3 Voice Siren Driver	Voice siren driver with English, Spanish and French voice messages. Separate messages for Fire and Burglary. Use with 8-ohm speaker. UL Listed.
Ademco 705–820, 5-inch Round Speaker	15-watt, 8-ohm speaker.
Ademco 713 Speaker	40-watt, 8-ohm, indoor/outdoor speaker.
System Sensor PA400B (beige)/PA400R (red) Indoor Piezo Sounder	Indoor piezo sounder (red or beige), rated at 90 dB @ 10 feet.

UL	<ul style="list-style-type: none"> • Use only UL Listed sounding devices for UL installations. • The total current drawn from the alarm output and the auxiliary power output, combined, cannot exceed 700 mA. In addition, the sounding device must be a UL Listed audible signal appliance rated to operate in a 10.2-13.8 VDC voltage range, and must be mounted indoors. Example: Wheelock Signals Inc. siren model 34T-12 (provides 85dB[A] for NFPA 74 & Standard 985).
-----------	---

This control complies with NFPA requirements for temporal pulse sounding of fire notification appliances.

Temporal pulse sounding for a fire alarm consists of the following:

3 pulses – pause – 3 pulses – pause – 3 pulses. . .

Sounder Connections

The VISTA-20AMT3 provides a 12VDC output which can power external alarm sounders (bells or sirens, see compatible sounders listed previously). This output will activate a sounder when an alarm occurs.

Make connections to alarm output terminals 3 (+) and 4 (-). See Figure 17.

Non-UL Installations

The total current drawn from this output cannot exceed 2 amps. A battery must be installed since this current is supplied by the battery.

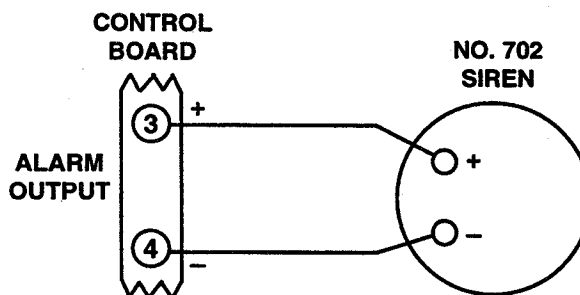
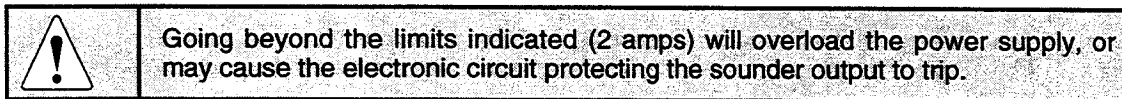

Figure 17. Typical Sounder Wiring

Testing the Sounder

After installation of the sounder is completed, the Security System should be carefully tested, as follows.

1. Connect the battery wires from the control board to the battery, observing correct polarity.
2. Enter the installer code and press the TEST [5] key on the keypad.
The external sounder should sound for 1 second if the sounder is good and proper connections have been made. Note that if the backup battery is discharged, the sounder will not turn on.
3. To turn off the test mode, enter the installer code and press the OFF key.

Section 10. LONG RANGE RADIO

General Information

Check availability of Models 7720 PLUS or 7820 long range radios.

If output to long range radio is selected, all messages that are programmed to go to the primary telephone line receiver will also be sent to the 7720 PLUS or 7820 long range radio. These messages will be in Contact ID format (not affected by entry in field *48).

UL

For UL installations, Long Range Radio must be disabled (*29 = "0").

The data line is supervised, as well as certain functions in the radio. If communication is lost or a trouble develops, a message will be attempted to be sent via both radio and telephone to the central station.

For complete information, see the manual that accompanies the radio.

Connection

Connect the data in/data out terminals and voltage input terminals of the No. 7720 PLUS or 7820 Long Range Radio to the control's keypad connection points, terminals 4, 5, 6, and 7 as shown below.

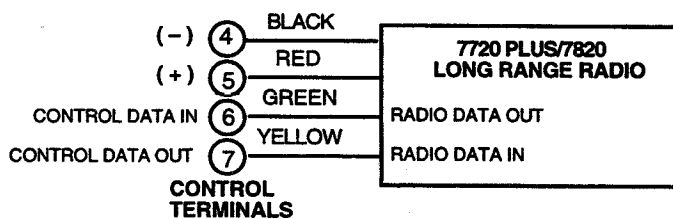

Figure 18. Long Range Radio Connections

Section 11. REMOTE KEYSWITCH

This section provides instructions for the connection of an optional remote 4146 keyswitch for remote arming and disarming of the system, and the programming necessary when a keyswitch is used. Also included is a description of how the keyswitch operates in the system.

Installing the Keyswitch

The remote 4146 keyswitch (with red and green LEDs to indicate status) is connected to zone 7.

Remote Keyswitch Connections

1. Connect the 4146 keyswitch's normally open momentary switch to zone 7 terminals (18 and 19). Remove the 2000 ohm EOL resistor if connected across zone 7 terminals.



When zone 7 is used for keyswitch usage, zone 7 is no longer available for use as a protective zone.

2. Connect the Red and Green LEDs to pins 7, 8, and 9 on the 9-pin connector, using a 4142TR cable as shown in Figures 19 (A) and (B).
3. Connect a 2000 ohm EOL resistor across the momentary switch.
4. You can wire an optional closed-circuit tamper switch (model 112) in series with the zone. If the switchplate is then removed from the wall, the tamper will open, disabling keyswitch operation until the system is next disarmed from the keypad.

If the tamper (or zone 7 loop wires) is opened when the system is armed, an alarm will occur.



If you are using more than one keyswitch, connect the EOLR at the last switch. The momentary arming switches must all be across the loop and the tamper switches in series with it. The LEDs will not be as bright since they will be sharing drive current in this case.

The 4146 keyswitch can be used with only the Red and Green LEDs connected (omitting the lock switch and tamper switch) to simply provide an arming/ready status indicator panel (see "LED Indications" table under **Keyswitch Operation** at the end of this section). When so used, no connections are made to zone 7, which may then be used as a hardwired protection zone, **provided you do not enable field *30.**

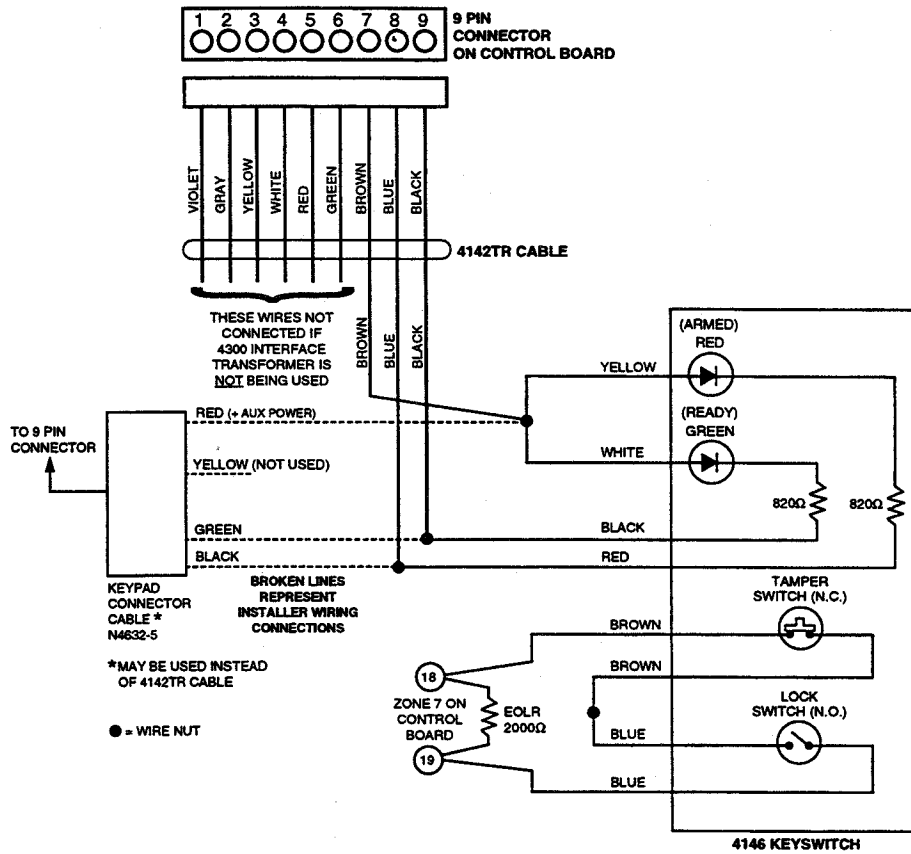

Figure 19 (A). Keyswitch Wiring (4300 Interface Transformer not used)

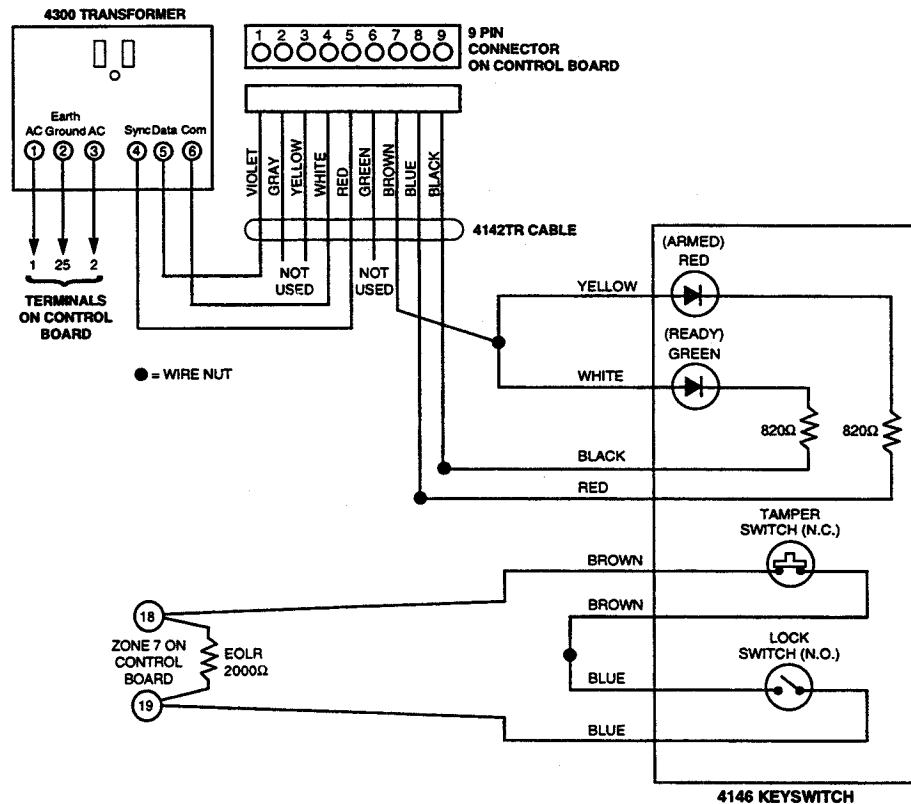

Figure 19 (B). Keyswitch Wiring (4300 Interface Transformer also used)

Programming For The Remote Keyswitch

1. With one 2-line Alpha keypad (6139AMT3), enter the programming mode by entering:

Installer code + 8 + 0 + 0 keys.



If RF zones, wired expansion, or a keyswitch will be used, data fields *22 RF SYSTEM, *25 WIRED ZONE EXPANSION and *30 KEYSWITCH ENABLE must be programmed as required prior to continuing.

Note: If keyswitch is enabled, in menu mode *56 the Zone Type (ZT) for zone 7 will show "77", and will not be accessible for programming.

2. **Press *56.**

Note that this is an interactive programming mode. You will use it to program zone 7 for alarm report codes and to program response time (zone type will automatically show as "77").

Enter Zn Num. (00 = Quit) 01
Zone Number ↑

Upon entering *56 mode, this prompt will be displayed.

Enter zone number "07".

Following this entry, press * to continue.

Typical summary display

Zn	ZT	RC	In	RT
07	77	00	HW:	1

A summary display will appear, showing the present status of zone 7's programming.

Zn = zone number;

ZT = zone type;

RC = report code for that zone;

In = input type of zone;

RT = response time for that zone.

Values displayed are the factory defaults for zone 7 or, if this is not a new installation, they are the currently programmed values.

↓ Zone Number

07 Zone Type 77
Zone Type ↑

To program zone 07, press [*].

Zone type will be automatically displayed as "77", and no entry is required.

Press [*] to continue.

07 Report Code
1st 03 2nd 12 3C

The report code consists of 2 hexadecimal digits, each in turn consisting of 2 numerical digits. For example, for a report code of "3C", enter [0][3] for "3" and [1][2] for "C".

If necessary, refer to *Section 23. SYSTEM COMMUNICATION* for complete information on report codes.

Enter the desired numbers and then press [*] to continue.

07 Response Time	1
------------------	---

If keyswitch is enabled (in programming mode, field *30), the response is preset to 350ms. Therefore no entry is required.

Press [*] to continue.

Typical summary display

Zn ZT	RC In RT
07 77	3C HW: 1

A summary display will appear, showing the data for zone 07 that was just programmed. If it is programmed satisfactorily, press [*] to continue.

Program Alpha?
0 = No 1 = Yes 0

The next request is to enter an Alpha descriptor for zone 7. Since this is a keyswitch zone, no descriptor is required. Enter "0".

Enter Zn Num.
(00 = Quit) 08

If "0" (no) was entered above, the system will display a prompt for entry of the number for the next zone.

Press [0] [0] plus [*] to exit *56 mode.

Exit the programming mode by keying *99.

Keyswitch Operation

To arm AWAY, turn key and release within a 1/2 second. To arm HOME, turn and hold key for longer than 2 seconds. To disarm, turn key and immediately release.

LED indications are defined as follows:

GREEN	RED	MEANING
OFF	OFF	DISARMED & NOT READY
ON	OFF	SYSTEM READY
OFF	ON STEADY	ARMED AWAY
OFF	SLOW FLASH	ARMED HOME
OFF	RAPID FLASH	ALARM MEMORY

Section 12. AUDIO ALARM VERIFICATION (AAV) UNIT

General Information

An Audio Alarm Verification (AAV) module, such as the Eagle 1241, is an add-on accessory that permits voice dialog between an operator at a central station and a person at the alarm installation, for the purpose of alarm verification.



In addition to entering option "4" in field *91 OPTION SELECTION, Contact ID report format must be selected for the primary phone number, and alarm reports must be programmed for the primary phone number to enable the AAV feature.



AAV cannot be used if paging is also enabled.

UL

The AAV option cannot be used in UL installations.

After all messages have been sent during a reporting session to the primary phone number, the control will trigger the AAV if at least one of the messages was an alarm report. The control will send a "listen-in to follow" message (Contact ID event code 606), which signals the 685 to hold the phone connection for 1 minute.

Once the digital message is "kissed off", the control will give up the phone line to the AAV module, without breaking connection with the central station. At this time, all sirens and all continuous keypad sounds will be shut off.



You must connect a 4204 or 4229 relay module when using an AAV unit. Do not use relay output number 1 for any other usage.

Wiring Connections

The method used to trigger AAV is via the use of a 4204 or 4229 relay module, as shown in the AAV connection diagrams that follow (one diagram for connections when a 4285 Phone Module is used, the other when the 4285 is not used).

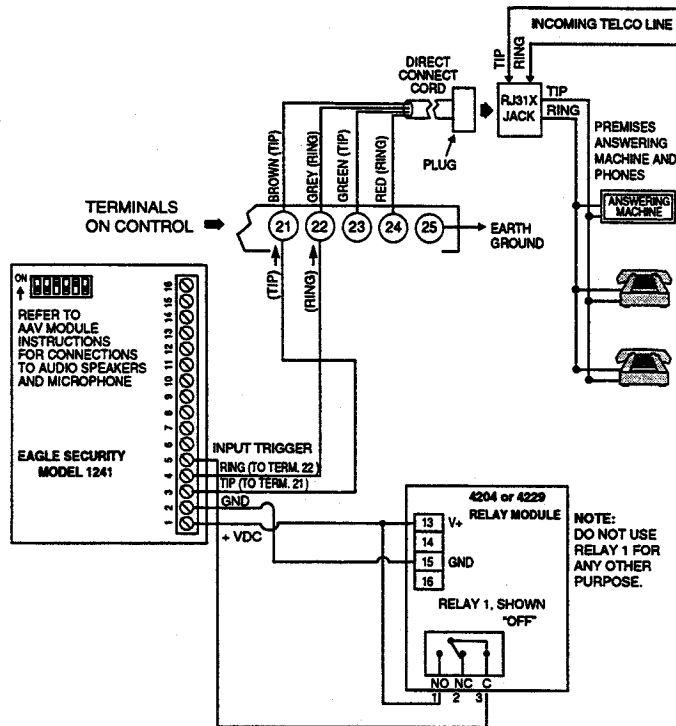

Figure 20. Connection Of AAV Unit When Not Using A 4285/4286 Phone Module

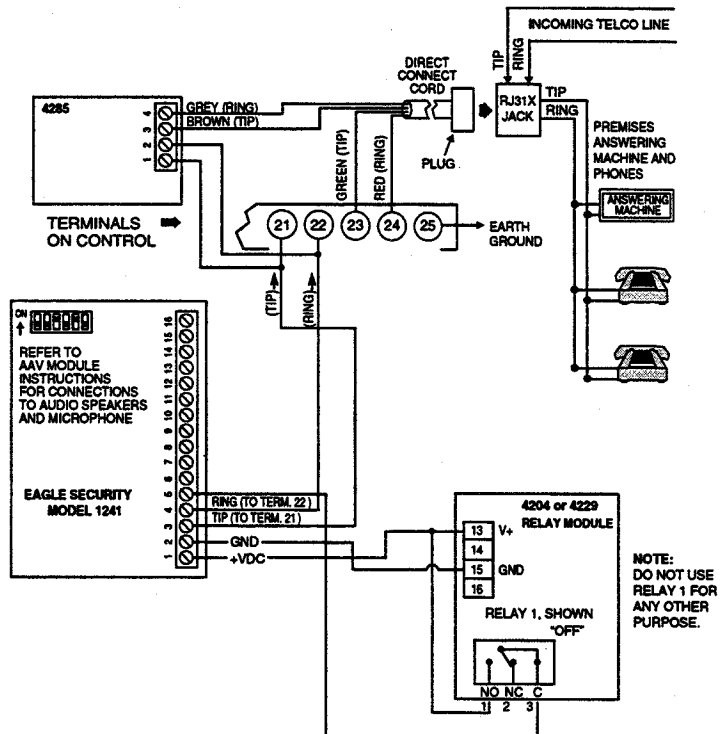

Figure 21. Connection Of AAV Unit When Also Using A 4285 or 4286 Phone Module

Section 13. FINAL POWER UP

This section provides information about final power-up procedures and battery size calculations.

Earth Ground Connections

The designated earth ground terminal (25) must be terminated in a good earth ground for the lightning transient protective devices in this product to be effective. It also must be grounded to enable the telephone line fault indicator to work properly. The following are examples of good earth grounds available at most installations:

Metal Cold Water Pipe: Use a non-corrosive metal strap (copper is recommended) firmly secured to the pipe to which the ground lead is electrically connected and secured.

AC Power Outlet Ground: Available from 3-prong, 120VAC, power outlets only. To test the integrity of the ground terminal, use a three-wire circuit tester with neon lamp indicators, such as the UL-Listed Ideal Model 61-035, or equivalent, available at most electrical supply stores.

AC Power-Up

1. Plug the 1321 or 4300 transformer into a 24-hour, uninterrupted 120VAC outlet.
2. Following power-up, **AC**, **dI** (disabled), or **Busy Standby** (Alpha keypads) or **NOT READY** (fixed-word keypads) will be displayed. Also the green "POWER" LED* on the keypad(s) should light.

* Some keypads are equipped with a "READY" LED in place of a "POWER" LED.

After approximately 1 minute, the initial displays will revert to ****SYSTEM READY**** for Alpha keypads, or **READY ENTER CODE** for Fixed-word keypads (if there are no faulted zones). This 1-minute delay allows PIRs, etc. to stabilize.

To bypass this delay, press: [#] + [0].

Connecting The Back-Up Battery

In the event of an AC power loss, the Control panel is supported by a back-up, rechargeable gel cell battery. The minimum battery size recommended is the No. 467 (12V, 4AH) battery. See "Calculating Battery Size Needed" below. The battery is installed in the control cabinet.

The standby battery is automatically tested every 4 hours, beginning 4 hours after exiting programming mode. In addition, entry into the test mode will cause a battery test to be initiated.

Calculating the Battery Size Needed

Determine the total device current draw after filling in the **AUXILIARY DEVICE CURRENT DRAW WORKSHEET** on the next page. To this figure add the 100 mA that is drawn by the control panel itself. Then, to determine the battery size needed, use the following formula:

Total Current Drawn* x Number of hours standby wanted = Battery Ampere/Hours.

* Convert mA figure to decimal Amps (see example).

Example: If total auxiliary device current drawn is 450 mA, add 100 mA for the control panel, for a total of 550 mA (0.55 amps); if 24-hour standby is wanted, the calculation will be:

$$0.55 \text{ mA} \times 24 \text{ hours} = 13.2 \text{ Ampere/Hour battery needed.}$$

In this example, two 7 Amp/Hr batteries (connected in parallel) must be used.

Making the Battery Connections

1. Use the battery standby formula (above) to select the appropriate battery for the installation.



Do not connect the battery until all devices have been wired to the control.

2. Attach the Red and Black wires on the battery connector cable as follows:
 - a) Red to the positive (+) battery tab on the control board.
 - b) Black to the negative (-) battery tab on the control board.

See the SUMMARY OF CONNECTIONS diagram (inside back cover) for location of the (+) and (-) battery tabs on the control board.
3. Attach the Red and Black wires at the other end of the battery connector cable as follows:
 - a) Red to the positive (+) terminal on the battery.
 - b) Black to the negative (-) terminal on the battery.

Battery Tests: The battery is periodically tested automatically (approximately every four hours), and if it cannot sustain a load, a low battery message is displayed and, if so programmed, will be reported to the central station.

In addition, the connection to the battery is checked every 3 minutes (CSFM requirement). If there is no battery detected, or a low battery condition detected, a low battery message is displayed and a report is sent to the central station.

AUXILIARY DEVICE CURRENT DRAW WORKSHEET

DEVICE	CURRENT	# UNITS	TOTAL CURRENT
6128AMT3 Keypad	30 mA		
6139AMT3 Keypad	100 mA		
5881/5882 RF Receiver	35mA		
4219 Zone Expander	35mA		
4204 Relay Unit	15/180mA‡		
4229 Zone Expander/Relay Unit	35/100mA‡		
4285 Phone Module	160mA		
4286 Phone Module	300mA		
*			
*			
*			
TOTAL =			
(Current available from Aux. terminals = 600 mA max.)**			

* If using hard-wire devices such as PIRs, refer to the specifications for that particular unit's current draw.

** In UL installations, maximum current draw from the Auxiliary Output and the Alarm Output combined must not exceed 700 mA (600 mA max from Auxiliary Output).

‡ Figures are for relays OFF/relays ON.

Section 14. MECHANICS OF PROGRAMMING

This section provides information on how to use the system's programming modes. It will enable you to understand how to enter and exit programming mode, and how to program the data fields and how to use the user-friendly interactive modes (*56, *80, *81, *82, *83).



If RF zones or wired expansion will be used, the following program fields **must** be programmed (as required) before doing any zone programming.

***22 RF-SYSTEM**

***25 WIRED ZONE EXPANSION**

In addition, the following fields must be programmed before completing the installation.

***20 INSTALLER CODE**

General Programming Information

Characteristics for each installation are stored in non-removable, electrically erasable, non-volatile EEPROM memory. These must be programmed for the particular installation to establish its specific alarm and reporting features.

It is possible to program the system at any time, even at the installer's premises prior to the actual installation. Simply apply power temporarily to the control and then program the unit as desired.

IMPORTANT: You cannot enter the programming mode unless the security system is disarmed.

There are two programming modes: data field programming and interactive (menu) mode programming. Data field programming is used for setting various system options and interactive programming is used for programming zone information, programming relay outputs, and for enrolling transmitter serial numbers.



To program the system, you must use a 6139AMT3 2-line Alpha keypad connected to the keypad terminals on the control (4, 5, 6, & 7). **Also, the security system must be disarmed.** The Alpha keypad need not necessarily remain in the system after programming.

Programming can also be performed remotely from the installer's office/home, using an IBM personal computer, a modem, and V-Link downloading software. See the *REMOTE PROGRAMMING AND CONTROL (DOWNLOADING)* section.

Entering Program Mode

You may use one of the following methods:

- Press both the [*] and [#] keys at the same time **within 50 seconds after power is applied to the Control**, or
- After power up, enter the Installer code (4 1 1 2) + 8 0 0.

This method is disabled if you exit the program mode using *98 instead of *99. See "Exiting Program Mode" paragraph later in this section.

If a different Installer code is subsequently programmed, use it instead of 4112 to gain access to the Programming mode.

Following entry into program mode, data field *20 will be displayed (this is the first data field in the system). The system will now accept entries for field *20.

Programming a Data Field

- Press [*] plus Field No. (for example, *21), then make the required entry.
- When you have completely programmed a data field, the keypad will "beep" three times and then automatically display the next data field in sequence. To go to a different field, press [*] plus the desired field No.

3. If the number of digits that you need to enter in a data field is less than the maximum digits available (for example, the phone number field), enter the desired data, then press [*] and the next data field number to be programmed.
4. If you try to enter a non-existent field, the keypad will display **EE** or **Entry Error**. Simply re-enter [*] plus a valid field number.

Reviewing a Data Field/Erasing an Entry in a Data Field

Press [#] plus Field No. Data will be displayed for that field number. **No changes will be accepted in this mode.**

To delete an entry in a field, press [*] plus Field No. + [*]. (Applies only to fields *40–*44, *88, and *94).

Interactive Mode Programming (*56, *80, *81, *82 and *83)

Typical prompt displayed during interactive mode programming

Enter Zn Num. (00 = Quit) 01
Zone Number ↑

Press [*] plus **interactive mode no.** (for example, *56). The Alpha keypad will display the first of a series of prompts requesting entries. A detailed procedure (with displays of prompts) is provided in later sections of this manual.

Interactive Mode	Used To Program
*56 Zone Programming	Zone characteristics, report codes, alpha descriptors and serial numbers
*80 Relay Programming	4229 or 4204 Relay modules, or Powerline Carrier devices
*81 Zone List Programming	Zone Lists for relay/powerline carrier activation
*82 Alpha Programming	Zone alpha descriptors
*83 Sequential Mode	5800 series transmitter serial numbers

Loading Factory Defaults

To load the factory defaults, enter the programming mode, press *97, then exit the programming mode.



Do not press *97 to load defaults if any programming has been done previously—data already programmed into the system will be changed!

***96** resets all the Subscriber Account numbers and CSID in preparation for an initial download.

Programming System Setup Fields

The following program fields **must** be programmed before doing any zone programming.

***22 RF SYSTEM** 0
 Enter 1 if 5881/5882 RF receiver is being used; enter 0 if no receiver is being used. Default is 0 (none).

***25 WIRED ZONE EXPANSION** 0
 Use this field to select the type of expansion unit being used, as follows:
 0 = none; 1 = 4219; 2 = 4229; 3 = 4204. Default is 0.

Exiting the Programming Mode

***99** allows re-entry into the program mode using Installer Code + 8 0 0.

***98** inhibits re-entry into the programming mode using the Installer code.

Section 15.

ZONE RESPONSE TYPE DEFINITIONS

General Information

You must assign a zone type to each zone, which defines the way in which the system responds to faults in that zone. Zone types are defined below.

- Type 00**
Zone Not Used
- Program a zone with this zone type if the zone is not used.
- Type 01**
Entry/Exit Burglary #11
- This zone type provides exit and entry delays whenever the zone is faulted if the control is armed in the AWAY or HOME modes. When the panel is armed in the INSTANT or MAXIMUM modes, no entry delay is provided. Entry delay #1 is programmable from 0 - 99 seconds.
- Exit delay begins whenever the control is armed, regardless of the arming mode selected, and is independently programmable from 0 - 99 seconds (field *34).
- This zone type is usually assigned to sensors or contacts on doors through which primary entry and exit will take place.
- Type 02**
Entry/Exit Burglary #22
- This zone type provides a secondary entry delay whenever the zone is faulted if the panel is armed in the AWAY and HOME modes. When the panel is armed in the INSTANT or MAXIMUM modes, no entry delay is provided. Entry delay #2 is programmable from 0 - 99 seconds.
- The programmed exit delay (field *34) begins whenever the control is armed, regardless of the arming mode selected.
- This zone type is usually assigned to sensors or contacts on doors through which secondary entry and exit will take place, and where more time might be needed to get to and from the keypad (typically used for a garage, loading dock, or basement door).
- Type 03**
Perimeter Burglary
- This zone type gives an instant alarm if the zone is faulted when the panel is armed in the AWAY, HOME, INSTANT or MAXIMUM modes. This zone type is usually assigned to all sensors or contacts on exterior doors and windows.
- Type 04**
Interior, Follower
- This zone type gives a delayed alarm (using the programmed Entry/Exit time) if the Entry/Exit zone is faulted first. Otherwise this zone type gives an instant alarm. This zone type is active when the panel is armed in the AWAY and MAXIMUM modes. **This zone type is bypassed automatically when the panel is armed in the HOME or INSTANT modes.** This zone type is usually assigned to a zone covering an area such as a foyer, lobby, or hallway through which one must pass upon entry (After faulting the entry/exit zone to reach the keypad to disarm the system).
- Since this zone type is designed to provide an instant alarm if the entry/exit zone is not violated first, it will protect an area in the event an intruder hides on the premises prior to the system being armed, or gains access to the premises through an unprotected area.
- Type 05**
**Trouble by Day/
Alarm by Night**
- This zone type will give an instant alarm if faulted when armed in the AWAY, HOME, INSTANT or MAXIMUM (night) modes. During the disarmed state (day), the system will provide a latched trouble sounding from the keypad (and a central station report, if desired). This zone type is usually assigned to a zone which contains a foil-protected door or window (such as in a store), or to a zone covering a "sensitive" area such as a stock room, drug supply room, etc. This zone type can also be used on a sensor or contact in an area where immediate notification of an entry is desired.

- Type 06
24-hour Silent Alarm** This zone type sends a report to the Central Station but provides no keypad display or sounding. This zone type is usually assigned to a zone containing an Emergency button.
- Type 07
24-hour Audible Alarm** This zone type sends a report to the Central Station, and provides an alarm sound at the keypad, and an audible external alarm. This zone type is usually assigned to a zone that has an Emergency button.
- Type 08
24-hour
Auxiliary Alarm** This zone type sends a report to Central Station and provides an alarm sound at the keypad. **(No bell output is provided)**. This zone type is usually assigned to a zone containing a button for use in personal emergencies, or to a zone containing monitoring devices such as water or temperature sensors, etc.
- Type 09
Supervised Fire
(With Verification on
Zone 1)** This zone type provides a fire alarm on short circuit and a trouble condition on open circuit. The bell output will pulse when this zone type is alarmed. This zone type is always active and cannot be bypassed. **This zone type can be assigned to a control panel basic wired zone, any zone in a wired zone expansion module, or wireless zones.** When used with zone 1 on the panel, 2-wire smoke detectors can be used. For an explanation of the "verification" function, refer to the "Operation" paragraph in a previous section titled **2-Wire Smoke Detector Installation**.
- Note: Only hardwired zone 1 can be programmed as a fire zone in UL installations. However, any wireless zone can be used as a fire zone.**
- Type 10
Interior w/Delay** This zone type gives entry delay #11 (using the programmed entry time), if tripped when the panel is armed in the Away mode. Entry delay begins whenever sensors in this zone are violated, regardless of whether or not an entry/exit delay zone was tripped first. *No entry delay* is provided if tripped when the panel is armed in the Maximum mode. *Exit* delay is present for *any* arming mode. **This zone type is bypassed when the panel is armed in the HOME or INSTANT modes.**
- Type 20
Arm-Home** This is a special-purpose zone type used with 5800 series wireless pushbutton units which will result in arming the system in the HOME mode when the zone is activated. Pushbutton units send zone number as a user number to central station when arming or disarming.
- Type 21
Arm-Away** This is a special-purpose zone type used with 5800 series wireless pushbutton units which will result in arming the system in the AWAY mode when the zone is activated. Pushbutton units send zone number as a user number to central station when arming or disarming.
- Type 22
Disarm** This is a special-purpose zone type used with 5800 series wireless pushbutton which will result in disarming the system when the zone is activated.
- Type 23
No Alarm Response** This zone type can be used on a zone when an output relay action is desired, but with no accompanying alarm (e.g., lobby door access).
- Type 24
Silent Burglary** This zone type provides an instant alarm, with NO audible indication at any keypad or external sounder, if the zone is faulted when the system is armed in the AWAY, HOME, INSTANT, or MAXIMUM modes. This zone type is usually assigned to all sensors or contacts on exterior doors and windows where bells and/or sirens are NOT desired. A report is sent to the Central Station.

NOTE: All of the zone types described are available for the wireless portion of the system, if used.

Section 16. DATA FIELD DESCRIPTIONS

Descriptions of System Data Fields

THE BLANK PROGRAMMING FORM SHOULD BE USED TO RECORD THE DATA FOR THIS INSTALLATION

Defaults (where applicable) Are Indicated In Text

The following pages list all data fields used in this control (in numerical order). If you have performed the programming instructions that were included with the installation of each of the various peripheral devices covered in previous sections, this table will simply serve as a reference for all data fields in the system. If you have decided to program all the data fields in the system at one time (and therefore did not perform the programming indicated previously in each section), you can use this listing to program all the data fields now.

- *20 INSTALLER CODE** 4 | 1 | 1 | 2
The Installer code is used to enter the 4-digit Master security code in the normal operation mode, via the keypad. See "Master Code" in the *SYSTEM OPERATION* section for procedure.
Enter 4 digits, 0-9.
- *22 RF SYSTEM** 0
0 = no RF receiver being used
1 = 5881/5882 RF receiver being used
- *23 FORCED BYPASS FUNCTION** 0
0 = no forced bypass
1 = provide automatic bypass of all open (faulted) zones
All zones bypassed by this function will be displayed after the bypass is initiated.
UL installations: must be 0 (no forced bypass)
- *24 RF HOUSE ID CODE** 0 | 0
00 = disable all wireless keypad usage
01-31 = House ID
The House ID identifies receivers and wireless keypads.
If a 5827 or 5827BD Wireless keypad or 5804BD transmitter is to be used, a House ID code **MUST** be entered, and the wireless keypad should be set to the same ID.
- *25 WIRED ZONE EXPANSION** 0
0 = no expander module connected
1 = 4219 connected
2 = 4229 connected
3 = 4204 connected
- *26 CHIME BY ZONE** 0
0 = no (chimes on fault of any entry/exit or perimeter zone when chime mode activated)
1 = yes (chimes on fault of specific zones programmed in relay zone list 3 when chime mode activated)
This option allows the installer to define the specific zones intended to chime when faulted while the system is in chime mode.

- *27 POWERLINE CARRIER DEVICE (X-10) HOUSE ID** 0
 Powerline Carrier devices require a House ID. This field identifies this House ID to the control.
 If Powerline Carrier devices are used, they are selected in field * 80.
 House ID is entered in following manner:
 0 = A, 1 = B, 2 = C, 3 = D, 4 = E, 5 = F, 6 = G, 7 = H, 8 = I, 9 = J,
 # + 10 = K, # + 11 = L, # + 12 = M, # + 13 = N, # + 14 = O, # + 15 = P.
- *28 PHONE MODULE ACCESS CODE** 0 | 0
 1-9 = first digit of access code
 * or # = second digit of access code (enter # +11 for "*", or # +12 for "#")
 The use of a 4285 Phone Module requires a 2-digit code.
 Example: If desired access code is 7*, 7 is the first entry, and # + 11 (for *) is the second entry.
NOTE: A "0" in either digit disables the Phone Module.
- *29 OUTPUT TO LONG RANGE RADIO (No. 7720PLUS/7820)** 0
 If output to LRR is selected here, all messages that are programmed to go to the primary telephone line receiver will also be sent to the 7720 PLUS or 7820 radio. These messages will always be in Contact ID format (not affected by entry in field *48). The data line is supervised as well as certain functions in the radio. If communication is lost or a trouble develops, a message will be attempted to be sent via both radio and telephone to the central station.
Note: Normal trouble restore report (*71) is sent on restore of the condition.
 Entry is first digit of Trouble Dialer Report; enter Trouble code 1-9, B (# +11), C (# +12), D (# +13), E (# +14), or F (# +15). The 2nd digit of Trouble Dialer Report is automatically the 2nd digit from field *60.
 UL installations: must be 0 (Long Range Radio disabled)
Note: The Radio should be programmed for device address 3 on the keypad lines.
- *30 KEYSWITCH ENABLE (ZONE 7)** 0
 0 = Disable
 1 = Enable
- *31 SINGLE ALARM SOUNDING PER ZONE (per armed period)** 0
 0 = no limit on alarm sounding per zone
 1 = limit alarm sounding to once per arming period for a given zone.
 UL installations: must be 0 (no limit)
- *32 FIRE SOUNDER TIMEOUT** 0
 0 = yes, fire sounder timeout after time programmed in field *33
 1 = no fire sounder timeout; continue sounding until manually turned off
 This control complies with NFPA requirements for temporal pulse sounding of fire notification appliances.
 Temporal pulse sounding for a fire alarm consists of the following:
 3 pulses - pause - 3 pulses - pause - 3 pulses. . .

- *33 ALARM BELL TIMEOUT** 1
- 0 = No timeout
 1 = 4 min
 2 = 8 min
 3 = 12 min
 4 = 16 min
- This field determines whether the external sounder will shut off after time allotted, or continue until manually turned off.
 UL installations: must be set for a minimum of 4 min (option 1)
- NOTE:** If the fire sounder of *32 is programmed for no timeout with *33 programmed for 4 to 16 minutes of alarm bell ringing, and a burglary alarm is triggered at the same time a fire is detected, the alarm bell will timeout as specified in *33.
- *34 EXIT DELAY** 9 | 9
- 00 - 99 = exit delay time in seconds
 The system will wait the time entered before sounding an alarm if the exit door is left opened after the system has been armed.
- *35 ENTRY DELAY 1** 6 | 0
- 00 - 99 = entry delay time in secs.
 The system will wait the time entered before sounding alarm upon entering.
 UL installations: must be set for a maximum of 20 seconds
- *36 ENTRY DELAY 2** 9 | 0
- 00 - 99 = entry delay time in secs.
 The system will wait the time entered before sounding alarm upon entering.
 UL installations: must be set for a maximum of 20 seconds
- *37 AUDIBLE EXIT WARNING** 1
- 0 = no exit warning sound
 1 = provide exit warning sound when armed AWAY
- Warning sound consists of slow continuous beeps until last 5 seconds, when it changes to fast beeps. The warning sound will end at the termination of Exit time.
- *38 CONFIRMATION OF ARMING DING** 0
- 0 = no ding
 1 = confirmation ding after arming system
 2 = confirmation ding after arming from RF button or RF keypad only (ding occurs when the system receives the RF transmission.)
- Confirmation of arming is 1/2 second external sounder "ding" when closing report is sent, or at the end of exit delay.
- *39 POWER UP IN PREVIOUS STATE** 1
- 0 = always power up in a disarmed state
 1 = assume the system status prior to power down
- When the system powers up armed, an alarm will occur 1 minute after arming if a zone is faulted.
- Note that if the previous state was armed AWAY or HOME, the system will not respond to sensor changes for 1 minute, which allows time for sensors such as PIRs to stabilize. This means that if a zone faults during that 1 minute time period, the system will not detect the faulting and would power up into the armed ON AWAY or ON HOME original state.
- UL installations: must be 1 (power up in previous state)

DIALER PROGRAMMING *40
 (*40 – *44 and *47 – *50)

Fields *40, *41, *42:

Enter up to the number of digits shown. Do not fill unused spaces.

Enter 0-9,

+ 11 for *

+ 12 for

+ 13 for a pause
 (2 seconds)

For Fields *43 and *44:

Enter digits 0-9; # +11=B; # +12=C; # +13=D; # +14=E; or # +15=F.

Enter [*] as the fourth digit if a 3-digit account number (for 3+1 dialer reporting format) is used. Enter 0 as the first digit of a 4-digit account number for Nos. 0000-0999. Exit field by pressing [*] (and press next field number) if only 3 digits are used.

To clear entries from field, press *43*, or *44*.

See blank Programming Form for examples of Account No. entries.

***40 PABX ACCESS CODE (See Box at Left)**

--	--	--	--	--	--

Enter up to 6 digits if PABX is needed to access an outside line. If fewer than 6 digits are needed to be entered, exit by pressing [*] and next field number (e.g., 41). To clear entries from field, press *40*.

***41 PRIMARY PHONE No. (See Box at Left)**

--	--	--	--	--	--	--	--	--	--	--	--	--	--	--	--	--	--	--	--

Enter up to 20 digits. If fewer than 20 digits entered, exit by pressing [*] and next field number (e.g., 42). To clear entries from field, press *41*.

Note: Back-up reporting (8 calls are made to the secondary phone number if no kiss-off is received after 8 attempts to the primary number) is automatic only if there is a secondary phone number (field *42).

***42 SECONDARY PHONE No. (See Box at Left)**

--	--	--	--	--	--	--	--	--	--	--	--	--	--	--	--	--	--	--	--

Enter up to 20 digits. If fewer than 20 digits entered, exit by pressing [*] and next field number (e.g., 43). To clear entries from field, press *42*. See back-up reporting note for field *41. If using the pager feature, enter the pager phone number here.

***43 PRIMARY SUBS ACCOUNT. No.**

--	--	--	--

See box at left.

***44 SECONDARY SUBS ACCOUNT. No.**

--	--	--	--

See box at left.

***47 PHONE SYSTEM SELECT**

3

If Central Station Receiver *is not* on WATS line:

0 = Pulse Dial

1 = Tone Dial

If Central Station Receiver *is* on WATS line:

2 = Pulse Dial

3 = Tone Dial

***48 REPORT FORMAT**

7	7
Prim.	Sec.

0 = 3+1; 4+1 ADEMCO Low Speed Standard

1 = 3+1; 4+1 Radionics Standard

2 = 4+2 ADEMCO Low Speed Standard

3 = 4+2 Radionics Standard

6 = 4+2 ADEMCO Express

7 = ADEMCO Contact ID Reporting

8 = 3+1; 4+1 ADEMCO Low Speed Expanded

9 = 3+1; 4+1 Radionics Expanded

Enter * as the 4th digit of *43 and *44, if 3+1 dialer reporting is to be used.

For an explanation of these formats, see the *SYSTEM COMMUNICATION* section.

Note: The maximum number of alarm and alarm restore reports during one armed period is determined by field *93.

Use options 0 - 5 when reporting to standard telephone receivers

	TO PRIMARY	TO SECONDARY
0 =	All reports	none, unless primary fails, then all
1 =	Alarms, Restore, Cancel	Others
2 =	All except Open/Close, Test	Open/Close, Test
3 =	Alarms, Restore, Cancel	All
4 =	All except Open/Close, Test	All
5 =	All reports	All

Use options 6 - 9 when reporting to a pager is desired

	TO PRIMARY	TO PAGING No.
6 =	All reports except Open/Close	Alarms, Open/Close for users 5-25 [‡] , Troubles
7 =	All reports	Alarms, Troubles
8 =	All reports	Alarms, Open/Close for users 5-25 [‡] , Troubles
9 =	All reports except Open/Close	Open/Close for users 5-25 [‡]

[‡] Will report users 5-16, and, if using wireless button-type devices, will report the zone number of the arm or disarm button (10-25). Open/Close for users 1-4 are not reported.

Pager Report Format

Entries 6 through 9 will send a report to a pager, using the following format:

AAAAAAAAAAAAAAAA - BBB - CCCC

where,

A = (Optional). Up to 16 digits for Account numbers, PIN numbers, or any additional data that will precede the 7-digit system status code BBB and CCCC (see **B** and **C** below). This optional data is programmed in field *88, PAGING CHARACTERS.

B = A 3-digit code that describes the event that has occurred in the system (see the explanation below).

C = A 4-digit User or Zone number, depending on the type of event that has occurred. For alarms or troubles, these digits represent the zone number. For openings (disarming) and closings (arming), these digits represent the user number. In this system, the first 2 digits will always be "00." Single digit zone or user numbers are also preceded by a "0". See the explanation below.

Summary:

Optional 16 digits* - AAAAAAAAAAAAAAAAAA - BBB - CCCC = 4-digit User or Zone #

*Programmed in field *88

+

3-Digit Event Code

The 3-digit Event codes (BBB) that can be sent are:

911 = **Alarms**. The 4-digit number (CCCC) that follows this code will be the zone number that has caused the alarm.

811 = **Troubles**. The 4-digit number (CCCC) that follows this code will be the zone number that has caused the trouble.

101 = **Open** (system disarmed). The 4-digit number (CCCC) that follows this code will be the User number.

102 = **Close** (system armed). The 4-digit number (CCCC) that follows this code will be the User number.

- *50 15-SECOND DIALER DELAY (BURGLARY)** 1
 0 = no dialer delay
 1 = provide 15-second delay of burglary alarm report (except zone type 24) to the central station, which allows time for the subscriber to avoid a false alarm transmission. This delay does not apply to zone type 24 alarms, which are always sent as soon as they occur.
 UL installations: must be 0 (no delay)
- *51 PERIODIC TEST REPORT** 0
 0 = no test report
 1 = once every 24 hours
 2 = weekly
 3 = once every 30 days
 Test Report Code entered in field *64 is sent. Reports with Subscriber No.
- *52 TEST REPORT OFFSET** 2
 0 = 24 hours after exiting program mode or download
 1 = 6 hours after exiting program mode or download
 2 = 12 hours after exiting program mode or download
 3 = 18 hours after exiting program mode or download
 This is the time to first report from programming or downloading.
- *53 SESCOA/RADIONICS SELECT** 0
 0 = Radionics (0-9, B-F reporting)
 1 = SESCOA (0-9 only reporting)
 Select 0 for all other formats.

**TO PROGRAM SYSTEM
 STATUS AND
 RESTORE REPORT
 CODES
 (*59 - *76, & *89)**

Report codes can be programmed using the interactive *56 Zone Programming Mode, or codes can be entered in data fields *59 - *76, *89. The following is a set of guidelines to be used for programming report codes. The actual report code digits that you enter depend upon the particular installation, and should be in agreement with you and the central station office receiving the signals. Use these guidelines to program this entire section.

With a 3+1 or 4+1 Standard Format: Enter a code in the first box: 1-9, A, B, C, D, E, or F. Enter "#+10" for A (this reports a "0" on some receivers), "#+11" for B, "#+12" for C, "#+13" for D, "#+14" for E, "#+15" for F.
 An entry of "0" in the *first* box will disable a report.
 An entry of "0" in the second box will result in automatic advance to the next field when programming.

With an Expanded or 4+2 Format: Enter codes in *both* boxes (1st and 2nd digits) for 1-9, or A-F, as described above.
 An entry of "0" in the first box will disable a report.
 An entry of "0" in the second box will eliminate the expanded message for that report.

With Ademco Contact ID Reporting: Enter a digit in the first box to enable the zone to report. Use a different digit for each zone until you have used up available digits. If the number of zones exceeds the number of available digits, begin with digit 1 again. This is an "enabling" code only and is not the actual code sent to the central station office. Entries in the second boxes will be ignored. For system status (non-alarm) codes, enter a "1" in the first box for all the system conditions you want to send to the central station.
 An entry of "0" in the first box will disable the report.

**SYSTEM STATUS
REPORT CODES
(*59 - *68)**

- *59 EXIT ERROR REPORT CODE** (See box on previous page)
- If the system is armed and an Entry/Exit or Interior zone is still open after the exit delay time has expired, an alarm will sound at the keypad and external sounder (keypad also displays "Exit Alarm"). If the system is disarmed before the end of the entry delay that immediately follows, the alarm sounding will stop **and no message will be sent to the central station**. The keypad will display CA (fixed-word keypads) or CANCELED ALARM (Alpha keypads).
- If the system is **not** disarmed before the end of the entry delay mentioned above, and an Entry/Exit or Interior zone is still open, an **"exit alarm" message will be sent to the central station if an Exit Error Report code is selected in this field**. The keypad will display EA (fixed-word keypads) or EXIT ALARM (Alpha keypads), and the alarm sounding will continue until the system is disarmed (or timeout occurs).
- An "Exit Alarm" condition will also result if a fault occurs in an exit or interior zone within 2 minutes following the end of the exit delay, and an "exit alarm" message will be sent to the central station.
- If Contact ID format has been programmed, the message will contain the zone number and error code 374 (Trouble-Exit Error) to define the alarm as an Exit Error (rather than E/E or Interior). If 4+2 format is used, the digit entered in this field will be sent followed by the second digit of the programmed alarm code for that zone. If 3+1 or 4+1 format is used, only the digit entered in this field will be sent. This message will go to the Primary Phone No. Under any of these conditions, no Restore message will be sent.
- If "0" is entered in this field, no special message will be sent, only the regular alarm and alarm restore code for the zone.
- *60 TROUBLE REPORT CODE** (See box on page 56).
- This will be sent if a zone goes into trouble.
- *61 BYPASS REPORT CODE** (See box on page 56).
- This will be sent when a zone is manually bypassed.
- *62 AC LOSS REPORT CODE**
- See box on previous page. Reports with Subscriber No. Timing of this report is random with up to a 4-hour delay. If AC restores before the report goes out, there is no AC restore report.
- *63 LOW BAT REPORT CODE**
- This will be sent when a low battery condition exists in the system's standby battery. See box. Reports with Subscriber No.
- *64 TEST REPORT CODE**
- This is sent periodically to test that the communicator and phone lines are operational (frequency of report is selected in field *51). See box. Reports with Subscriber No.
- *65 OPEN REPORT CODE**
- This is sent upon disarming of the system. See box. 2nd digit = user number, if expanded or 4+2 reporting is selected.
- *66 ARM AWAY/HOME REPORT CODE**
- This option allows for independent programming of AWAY and HOME reports. 2nd digit of report is user number if expanded or 4+2 reporting is selected.
- NOTE:** OPEN reports are not sent in if the associated closing report is not enabled.

**RESTORE
REPORT CODES
(*70 - *76)**

- *67 RF XMTR LOW BATTERY REPORT CODE** 1 | 0

This is sent in the event that a wireless transmitter low battery condition exists. (See box on page 56).
- *68 CANCEL REPORT CODE** (See box on page 56). 1 | 0

This is sent upon disarming of the system after an alarm condition was reported.
- *70 ALARM RESTORE REPORT CODE, 1st DIGIT** 1

This is sent when the zone that caused an alarm is restored to its non-faulted condition. 2nd digit is automatically sent as the 2nd digit of the zone alarm report code programmed in field *56, if expanded or 4+2 reporting is selected.
- *71 TROUBLE RESTORE REPORT CODE** 1 | 0

See box. This is sent when a trouble in a zone is restored.
- *72 BYPASS RESTORE REPORT CODE** 0 | 0

See box on page 56. This is sent when a zone that has been bypassed is un-bypassed.
- *73 AC RESTORE REPORT CODE** 0 | 0

This is sent when AC power has been restored after an AC power outage. See box on page 56. Reports with Subscriber No.
- *74 LOW BAT RESTORE REPORT CODE** 1 | 0

This is sent when a system low battery condition is restored to normal. See box on page 56). Reports with Subscriber No.
- *75 RF XMTR LOW BATTERY RESTORE CODE** 1 | 0

See box on page 56. This is sent when a transmitter that previously sent in a low battery message has sent a message indicating it no longer has a low battery condition.
- *76 TEST RESTORE REPORT CODE** 0 | 0

This is sent when the test mode is exited. See box on page 56. Reports with Subscriber No. A restore code entered here will cause a restore message to be sent when Test mode is exited.
- *88 PAGER CHARACTERS** | | | | | | | | | |

| | | | | | |

Up to 16 digits may be entered in this field to signal a pager. Those 16 digits may be composed of a pin #, pauses, subscriber IDs, or any special digits that the end user specifies. All 16 digits do not have to be used. The preceding 16 digits (if any) will be followed by seven (7) more digits defined as follows:

 - a three (3) digit event code:
 - 911 = Alarm 101 = Opening (disarm)
 - 811 = Trouble 102 = Closing (arm AWAY)
 - a four (4) digit user/zone number:

The first two digits will always be 00 followed by the two digit user or zone #. Paging is enabled in the Split/Dual reporting field *49 by entering a number greater than 5.

NOTE: Some pagers may require an additional delay (pause) to be programmed into this field in order to receive the entire message. An entry of [#] + 13 = 2-second pause.
- *89 EVENT LOG 80% FULL REPORT CODE** 0 | 0

If an Event Logging selection is made in field *90, a message can be sent to the central station receiver when the log is 80% full. If the log becomes full, a new message will overwrite the oldest message in the log.

Note: Aside from the selection made by the installer in field *90, all control and readout from the log is accomplished via the Downloader.

***90 EVENT LOGGING**

15

- 0 = No event logging
- 1 = log Alarm/Alarm Restore
- 2 = log Trouble/Trouble Restore
- 4 = log Bypass/Bypass Restore
- 8 = log Open/Close
- x = log combination of events (add value of entries) *Example:* To select "Alarm/Alarm Restore", and "Open/Close", enter 9 (1 + 8); the selection of "3" = alarm/alarm restore (1) plus trouble/trouble restore (2). The default (15) selects all events.

The VISTA-20AMT3 system has the ability to record various events in a history log (48-event capacity). The types of events to be logged can be selected as indicated. At any time, the downloader operator can then upload the log and view or print out all or selected categories of the log. The log can also be cleared by the downloader operator.

The display/printout at the central station will show the date, time, event, and description of the occurrences. The time is calculated by an internal clock at the central station computer. Note that the time for any events that occur prior to a system power-down or an entry into the programming mode cannot be calculated by the central station computer. The time will then appear on the log as "unknown."

NOTE: System messages are logged when any non-zero selection is made.

***91 OPTION SELECTION (Audio Alarm Verification)**

8

- 0 = not using AAV
- 4 = an Audio Alarm Verification (AAV) unit is connected to the system
- 8 = Enable Exit Delay Restart (When * key is pressed after system is armed in HOME mode and exit delay has expired).
- 12 = AAV and Exit Delay Restart
- UL installations: must be 0 (AAV Exit Delay Restart disabled)

***92 PHONE LINE MONITOR ENABLE**

0

- 0 = Not used
- 1 = Local keypad display only when phone line is faulted
- 2 = Local keypad display plus keypad trouble sound when line is faulted
No automatic timeout.
- 3 = Same as "2" above plus Device No. 2 STARTS. If system is armed, external sounder activates. External sounder will be turned off by normal bell timeout, or by security code plus OFF. Option 3 may be used even if a relay unit or Powerline carrier device is not connected to the control.

NOTE: Device number 2 must either be programmed to be STOPPED in field *80 or STOPPED by entry of security code + [#] + 8 + 2. Field *80 should be set to "0" for STOP.

This feature will not function properly unless the designated earth ground terminal (25) is connected to an earth ground. If it is not, you may get false line cut indications.

***93 NUMBER OF REPORTS IN ARMED PERIOD**

0

- 0 = reports limited to a total of 10
- 1 = unlimited number of reports
- This option can be used to limit the number of messages (alarm & alarm restore reports) sent to the central station in an armed period.
- UL installations: must be 1 (unlimited reports)

DOWNLOAD INFORMATION
(*94, *95)

***94 DOWNLOAD PHONE NUMBER**

--	--	--	--	--	--	--	--	--	--	--	--	--	--	--	--	--	--	--	--	--

Enter up to 20 digits as follows: 0-9, # +11 for "*", # + 12 for "#", # + 13 for a pause. Do not fill unused spaces. End field by entering *. To clear entries from field, press *94*.

***95 RING DETECTION COUNT FOR DOWNLOADING**

15

0-15 = number of rings before control picks up phone line
Refer to the chart below and program this field accordingly.

NOTE: If "15" is entered in field *95 to bypass an answering machine, and a 4285 Phone Module is included in the system, you should note the following:
When calling in from an off-premises phone, the user should make the initial call, allow 1 to 3 rings only, then hang up. The user should then call again. The Phone Module will now seize the line, and 2 long tones sound, followed by the usual voice prompt for the 2-digit access code. If this procedure is not followed, Phone Module operation will not be possible.

Phone Module	Answering Machine	Downloading	Field *95
Yes	No	No	Set for value other than "0" (1-14). This will enable the control panel to answer the phone call. Otherwise, it will not be possible to access the Phone Module
Yes	Yes	No	Set for a value higher than the number of rings for which the answering machine is set. Example: if machine is set for 4 rings, use a value of 5 or higher. This is recommended so that the Phone Module can still be accessed if the answering machine is turned off and does not answer the phone call.
Yes	No	Yes	Set for value other than "0" (1-14).
Yes	Yes	Yes	Enter 15. See note at left.
No	No	No	Enter "0."
No	Yes	No	Enter "0."
No	No	Yes	Enter 1-14.
No	Yes	Yes	Enter 15 to bypass answering machine.

OTHER PROGRAMMING COMMANDS

***56 ZONE PROGRAMMING MODE**

Interactive menu mode used for programming zone attributes and report codes. Refer to the *ZONE PROGRAMMING* section for procedure.

***80 OUTPUT DEVICES**

Interactive menu mode applicable only if field *25 is programmed for a 4229, 4204, or if Powerline Carrier devices are being used. Refer to the *OUTPUT DEVICES* section for detailed procedure.

***81 ZONE LISTS FOR OUTPUT DEVICES**

Interactive menu mode applicable only if *25 is programmed for a 4229, 4204, or if Powerline Carrier devices are being used. Refer to the *ZONE LIST* section for detailed procedure.

***82 CUSTOM ALPHA EDITING**

Interactive menu mode used to program zone descriptors. Refer to the *ALPHA DESCRIPTION PROGRAMMING* section for procedure.

***83 SEQUENTIAL MODE**

Interactive menu mode used to "enroll" RF transmitter serial numbers. Refer to the *SEQUENTIAL MODE* section for detailed procedure.

***96 INITIALIZE DOWNLOAD ID AND SUBSCRIBER ACCT. No. FOR DOWNLOADING**

Pressing *96 initializes the system for downloading.

***97 SET ALL PROGRAM FIELDS TO DEFAULT VALUES**

Pressing *97 automatically loads all defaults and erases any information previously programmed.

***98 EXITS PROGRAMMING MODE**

Prevents re-entry by : Installer Code + 8 + 0 + 0
Allows re-entry only by Power-up then [*] and [#].

***99 EXITS PROGRAMMING MODE**

Allows re-entry to program mode by: Installer Code + 8 + 0 + 0 or by Power-up then [*] and [#].

Section 17. ZONE PROGRAMMING (* 56 Menu Mode)

While in program mode, press *56 to enter Zone Programming Menu Mode.

Refer to the zone assignment table for *56 on the separate programming form .

This is an interactive menu mode that is used to program zone numbers, zone types, alarm and report codes, and to identify the type of loop input device. This mode can also be used for "enrolling" 5800 series transmitter ID codes and for entering Alpha descriptors for zones (we recommend entering descriptors in menu mode *82).

NOTE: If using wireless transmitters, there are two methods for enrolling the transmitter serial numbers. The first method is by using *56 Zone Programming mode (described below). The second method is by using *83 Sequential mode. Note that the *83 Sequential mode requires that all zone information first be entered using *56 Zone Programming mode.

Program Tool: The Zone Programming and Sequential Modes allow you to use a 5803 or 5804 button-type transmitter as a "program tool." The upper left-hand and right-hand buttons of the tool duplicate the [*] and [#] keypad programming functions. The advantage of using a program tool is that it enables remote enrollment. You can move to the physical location of the transmitter to be enrolled, press the upper left-hand button of the program tool, and then trip the intended transmitter. The transmitter that you use as the program tool can also be used as a transmitter in the system. If you plan to use an existing transmitter, it must first be enrolled into the system as its associated zones. You may then program it as the tool.

After entering *56, the following prompts are displayed:

If the system has been set up to use wireless transmitters, and a program tool has been entered, skip to the zone number prompt. If no program tool has been entered, the following prompt will appear:

PROGRAM TOOL?
0 = NO, 1 = YES 0

00 INPUT S/N: L
A XXX-X XXX

00 INPUT S/N: L
A123-4567 3

If a program tool (5803/5804) is being used, enter "1." If not using a tool, enter "0" and skip to the zone number prompt.

If "1" is entered, the system will prompt for the serial number of the transmitter being used as the program tool. You can enter the serial number using one of the following methods:

- Enter the 7-digit serial number for the transmitter
- or
- Press any button on the transmitter. The keypad should beep twice and display the serial number of the tool.

In this example, the serial number is A123-4567. Once entered, you can use the 5803/5804 program tool to ready the system for enrolling a transmitter's serial number by first pressing the upper left-hand button of the program tool, then activating the desired transmitter (see procedure at the "enroll S/N?" prompt).

To back up to the "PROGRAM TOOL ?" prompt, press the [#] key on the keypad.

The serial number for the program tool will only remain in the system until the programming mode is exited. (Entering *97 will not delete the tool.)

Press [*] to continue.

Enter Zn Num.
(00 = Quit) 10

Zone 20 entered ↑

Zn ZT P RC In: L
10 03 1 10 RF: 1

↓ Zone Number

10 Zone Type
Perimeter 03

Zone Type ↑

Zone Number (Zn): Enter the zone number that you wish to program (or 00 to exit zone programming). Press [*] to continue.

A summary display appears, showing the status of that zone's programming.

If it is programmed satisfactorily, press [#] to back up one step and enter another zone number, if desired.

If the zone is not programmed, or you want to make changes, press [*] to continue.

Zone Type (ZT): Each zone must be assigned to a zone type which defines the way in which the system responds to faults in that zone.

Enter the zone type code (or change it, if necessary). Zone types are listed below.

00 = Not Used	06 = 24 Hr Silent	20 = Arm-Home
01 = Entry/Exit #1	07 = 24 Hr Audible	21 = Arm-Away
02 = Entry/Exit #2	08 = 24 Hr Aux	22 = Disarm
03 = Perimeter	09 = Fire W/verif.	23 = No Alarm Response
04 = Interior Follower	10 = Interior w/Delay	24 = Silent Burglary
05 = Trouble Day/Alarm Night		

Default values for zones 01 to 08 are:

Zone No.(Zn):	01	02	03	04	05	06	07	08
Zone Type Default:	09	01	01	03	03	03	04	04
Response Time Default *	1	1	1	1	1	1	1	1

* "1" for response time = 350 msec.

Press [*] to continue.

10 Report Code
1st 03 2nd 12 3C

Report Code (RC): The report code consists of 2 hexadecimal digits, each in turn consisting of 2 numerical digits. For example, for a report code of "3C", enter [0][3] for "3" and [1][2] for "C."

Enter the numbers and press [*] to continue.

10 INPUT DEV: LP#
RF TRANS. RF: 1

Input Device (In): For the 8 built-in hardwired zones, the Input Device types are automatically displayed as HW (Panic, Duress, and Tamper inputs are not applicable). For the auxiliary wired zones or RF transmitters, enter the input device type as follows:

2 = AW (auxiliary wired zone)
3 = RF (supervised RF transmitter)
4 = UR (unsupervised RF transmitter)
5 = BR (button type RF transmitter - unsupervised)

Refer to the "5800 Series Transmitters Table" in the *WIRELESS EXPANSION* section for the specific procedure required to "enroll" a particular transmitter.

Press [*] to continue.

10 INPUT DEV: LP#
RF TRANS. RF: 1

Loop number (LP#): Enter the loop number (1-4) for the zone of the transmitter being enrolled. The default is loop "1." To accept this, press [*]. If a different loop number is being used on this transmitter, enter the desired loop number and press [*] to continue (see the transmitter's Installation Instructions for specific loop designations). **The loop number must be entered here, whether using Zone Programming or Sequential Mode to "enroll" transmitters.**

10 LEARN S/N?
0 = NO, 1 = YES 0

If the transmitter's serial number has not been previously "enrolled," you may enter the enroll mode now by either entering "1" (YES) or by pressing the upper left-hand button of the program tool. **If using the program tool, move to the physical location of the transmitter to be enrolled before pressing the button.** A single short beep will verify that the button has been pressed. The system will respond to the first serial number transmitted after the [*] key on the keypad or the button of the program tool is pressed. Enter "0" (NO) if you wish to enroll the transmitter later, using the "*83 sequential" mode described in the *SEQUENTIAL MODE* section later in this manual. If "0" is entered, skip to the summary screen prompt.

10 INPUT S/N: L
A XXX-XXXX

This prompt is displayed if "1" (YES) is entered in response to the "Learn S/N?" prompt. The serial number may be enrolled by one of two methods:

- a) Enter the 7-digit serial number printed on the transmitter using an alpha keypad
- or
- b) Activate the transmitter by faulting or restoring the input you wish to use for that zone (e.g., press a button, open or close a door, etc.).

10 INPUT S/N: L
A002-4064 1

The system will enroll the serial number of the first transmitter heard, add the loop number entered to this serial number, display the serial and loop numbers, and cause the keypad to beep twice.



If the serial and loop number combination is already present in the system, a single long beep will be heard from the keypad. If this happens, the system will not display the serial number, but will wait for a transmission from another transmitter or transmitter loop input.

The system will then enter an optional confirmation mode so that the operation of the actual programmed input can be confirmed. Activate the loop input or button that corresponds to this zone. **We recommend that you confirm the programming of every transmitter before proceeding to the next zone.**

10 CONFIRMED
A022-4064 1

When the system sees activity on the appropriate input, it will beep three times and display the confirmation message.



At any time during this step, you may press the [*] key on the keypad or the upper left-hand button of the program tool if you are satisfied with the serial and loop number combination that has been enrolled, regardless of whether or not the enrolled input has been "confirmed."

If the incorrect transmitter has been enrolled, press the [#] key on the keypad or the upper right-hand button of the program tool to delete the serial number and return to the "LEARN S/N" prompt. A single long beep will be heard from the keypad to verify pressing of the upper right-hand button. Then, press "1" (YES) or press the upper left-hand button of the program tool (a single short beep will verify the system is ready for enrolling) and re-activate the proper transmitter or transmitter loop input.

ZN ZT P RC IN: L
10 03 1 3C RF: 1s

The summary screen for the zone will appear. Note that an "s" indicates that a serial number has, in fact, been enrolled. The cursor will be flashing above the loop number. Press [*] to accept the zone information.

NOTE: If you entered "0" in the "LEARN S/N?" prompt previously, you will not get an indication that the serial number has been enrolled.

If you want to delete the serial number, enter "0" and press [*]. The system will then prompt, "DELETE S/N?" Press the "1" (YES) key to complete the delete sequence. This process deletes the serial number only, *not* the loop number. The assumption is that the proper loop number was programmed, but the wrong serial or loop number was enrolled. To change the loop number, you must go back through zone programming for that zone and manually enter the loop number over the existing one.

PROGRAM ALPHA?
0 = NO 1 = YES 0

If you want to program alpha descriptors now, enter "1" (YES). See the *ALPHA DESCRIPTOR PROGRAMMING* section for more information.

If not, enter "0" (NO).

ENTER ZN NUM.
(00 = QUIT) 11

This will return you to the ENTER ZN NUM. prompt for the next zone. When all zones have been programmed, enter "00" to quit.

If you plan to enroll serial numbers in the sequential mode, enter "00" to quit, then go to the *SEQUENTIAL MODE* section later in this manual to enroll the serial numbers.



When you have finished programming all zones (including all serial numbers), test each zone using the system's TEST mode. Do not use the Transmitter ID Sniffer mode for this, as it will only check for transmission of one zone on a particular transmitter, and NOT the zones assigned to each additional loop.

Programming Options Defined

The following will help you understand the programming of Output Devices when using *80 and *81 modes. The options used to start and stop these devices are described below, followed by the actual screen prompts and available entries.

The letter(s) in parentheses after each function described below, such as (A) after ACTION, are those that appear in the various summary displays of programmed data during programming.

ACTION (A) The "ACTION" of the device is how the device will respond when it is activated by the "START" programming. There are four different choices of actions:

- ACTIVATE for 2 SECONDS and then reset.
- ACTIVATE and REMAIN ACTIVATED until stopped by some other event.
- PULSE ON and OFF until stopped by some other event.
- NOT USED when the device is not used.

START (STT) The "START" programming determines when and under what conditions the device will be activated. The following START options are available:

Start By Event

1. Event (EV) is the condition (Alarm, Fault, Trouble) that must occur to a zone or group of zones (zone list) in order to activate the device. These conditions apply **only** when a zone list is used. The different choices for "EVENT" are listed below and in the "Programming Output Relays & Powerline Carrier devices" section that follows.
 - ALARM Relay activates upon any alarm in an assigned zone in the zone list.
 - FAULT Relay activates upon any opening or short in an assigned zone in the zone list.
 - TROUBLE Relay activates upon any trouble condition in an assigned zone in the zone list.
 - NOT USED Relay action is not dependent upon one of the above events.
2. Zone List (ZL) is a group of zones to which the "EVENT" applies in order to activate a particular device. Note that there are a total of 3 output device related zone lists that can be programmed in *81 menu mode; when the selected EVENT (Alarm, Fault or Trouble) occurs in **any** zone in the selected "Start" ZONE LIST (1, 2, or 3), activation of the selected device will START.

Start by Zone Type or System Operation

1. If a System Operation, such as "DISARMING" or "ANY FIRE ALARM," is to activate the device, the appropriate choice would also be entered under the "ZONE TYPE" option. "ZONE TYPE" is used independently of the "EVENT/ZONE LIST" combination.

If a "ZONE TYPE" is chosen, any zone of that response type going into alarm, trouble, or fault will cause the device to activate as selected in "ACTION." If the same "ZONE TYPE" is also chosen for the STOP programming, any zone of that type that restores will de-activate the device.

If a "SYSTEM OPERATION" is chosen (e.g., End of Exit Time), that operation will cause the device to activate as selected in "ACTION." The different choices for "ZONE TYPE" and "SYSTEM OPERATION" are listed in "Programming Output Relays & Powerline Carrier Devices" later in this section, and in the Programming Form.

STOP (STP): The "STOP" programming determines when and under what conditions the device will be de-activated. The following options are available:

Upon Restore of a Zone List

1. Restore Zone List (ZL): If a "ZONE LIST" is used as the "Stop" event, the device will de-activate when all the zones in that list restore from a previous fault, trouble, or alarm condition. This will occur regardless of what is programmed to "START" the device; therefore, a "RESTORE ZONE LIST" would normally only be used when a "ZONE LIST" is used to start the device.

Upon a Zone Type or System Operation

1. Zone Type/System Operation (ZT): Instead of using a "RESTORE ZONE LIST", a specific zone (response) type or system operation action can be selected to de-activate the device.

If a specific "ZONE TYPE" is chosen, any zone of that response type that restores from a previous alarm, trouble, or fault condition will cause the device to de-activate.

If a "SYSTEM OPERATION" is chosen, that operation will cause the device to de-activate. The different choices for "ZONE TYPE" and "SYSTEM OPERATION" are listed in "Programming Relays & Powerline Carrier devices" later in this section, and in the Programming Form.

	<p>During normal system operation, any devices may be manually started by keypad entry of: Code + # + 7 + "n" or manually stopped by keypad entry of: Code + # + 8 + "n," where "n" = the device number to be controlled. As a minimum, the ACTION (A) field must be programmed for this manual action to be operative.</p>
---	--

	<p>If a relay is energized before a 4-wire smoke detector is reset, the relay will be stopped by the interruption of Aux. Power that resets the smoke detector. If this is not desired, the power to the relay unit should be supplied from another 12V power source (e.g., the same source that is powering external equipment through the relay contacts).</p>
---	---

Programming Output Relays and Powerline Carrier Devices

While in program mode, press *80 to enter Output Device Menu Mode. This mode is used to program all output devices used in the system (4229 or 4204 Relay modules, or Powerline Carrier devices). Refer to the output device table for *80 on the separate programming form when programming output devices.

NOTE: If using Powerline Carrier Devices, the House ID of the devices must be entered in data field *27.

After entering *80, the following prompts are displayed.

Output Device Displays

```
Enter Device No.
(00 = Quit)      01
```

Enter the Device Number 01 or 02 for a 4229, or 01, 02, 03, or 04 for a 4204, or 01 - 08 for Powerline Carrier devices (or 00 to end these entries). Press the [*] key to continue.

The [*] key is used to accept an entry and advance to the next prompt. The [#] key is used to revert back to the last question to check or change an entry. Press [*] to go forward again.

```
02  A EV ZL ZT
STT 0 0 0 00
```

This screen displays a summary of the current Device START programming (for this example, device 02 has been selected). Press the [*] key to continue.

```
02  A EV ZL ZT
STP - - 0 00
```

This screen displays a summary of the current Device STOP programming. Press the [*] key to continue.

```
02 Device Action
No Response      0
```

Enter the desired device action as listed below. Press the [*] key to continue.
 0 = No response 2 = Close and Stay Closed
 1 = Close for 2 seconds 3 = Continuous Pulse on & off (1 sec ON, 1 sec OFF)

```
02 Start Event
Not Used         0
```

Enter the event to START the relay:
 0 = Not used; 2 = Fault; 1 = Alarm; 3 = Trouble
 A zone list must be used in conjunction with an event. If a zone type/system operation is to be used instead of an event, enter 0. Press the [*] key to continue.

```
02 Start:   Zn List
No List     0
```

If a zone list will be used to START the relay action, enter the zone list number (to be programmed in field *81): 1, 2, or 3. If not used, enter 0. Press the [*] key to continue.

```
02 Start:   Zn Typ
Not Used    00
```

If a zone type or system operation will be used to START the device action, enter the appropriate two-digit code (see table that follows). If not, enter 00. Press the [*] key to continue.

CHOICES FOR ZONE TYPES

00 = Not Used	04 = Interior Follower	08 = 24 Hr Aux
01 = Entry/Exit #1	05 = Trouble Day/Alarm Night	09 = Fire
02 = Entry/Exit #2	06 = 24 Hr Silent	10 = Interior w/Delay
03 = Perimeter	07 = 24 Hr Audible	24 = Silent Burglary

CHOICES FOR SYSTEM OPERATION

20 = Arming-Home	36 = At Bell Timeout*	42 = System Battery Low
21 = Arming-Away	38 = Chime	43 = Communication Failure
22 = Disarming (Code + OFF)	39 = Any Fire Alarm	52 = Kissoff
31 = End of Exit Time	40 = Bypassing	58 = Duress
32 = Start of Entry Time	41 = AC Power Failure	
33 = Any Burglary Alarm		

* Use 0 (Any) at Disarming.

02 Start:	0
-----------	---

Enter 0 for any.
Press the [*] key to continue.

02 Stop:	Zn List	0
No List		

If a zone list will be used to STOP, or restore, the device action, enter the zone list number 1, 2, or 3 (to be programmed in *81 mode). If not used, enter 0.
Press the [*] key to continue.

02 Stop:	Zn Typ	00
Not Used		

If a zone type or system operation will be used to STOP the device action, enter the appropriate two digit code (see the "ZT" choices listed above). If not, enter 00. Press the [*] key to continue.

02 Stop:	0
----------	---

Enter 0 for any.
Press the [*] key to continue.

02	A	EV	ZL	ZT
STT	0	0	0	00

This screen again displays a summary of the current device START programming.
Press the [*] key to continue.

02	A	EV	ZL	ZT
STP	-	-	0	00

This screen again displays a summary of the current device STOP programming.
Press the [*] key to continue.

02 X10 Device ?	
0 = No, 1 = Yes	00

Enter 1 if using a Powerline Carrier Device (X-10); if not, enter 0.
The display then returns again to the first screen so that the next device number to be programmed can be entered, or enter [0][0] to end device programming.

Example of Output Device Programming

A lamp is to be turned on via a Powerline Carrier device (X-10) when any one of 3 specific zones are faulted, or when any 24-hour auxiliary zone is faulted. We want to be able to turn off the lamp **manually** without affecting the arming status of the system.

To program this, we would do the following:

- In *80 interactive mode we choose Output Device 01 and program the Action (A) to be "2" (Close and stay closed). The Event we are looking for to *start* the Device action is a fault, so we will program "2" in (EV). We will use Zone List 1 for the 3 specific zones, so we will program "1" in (ZL), (and we will program these 3 zones in *81's Zone List 1).
- The second condition for turning on the indicator is triggering a 24-hour aux. zone (Zone Type 08), so we will program (ZT) as "08."
- To stop the Device action and turn off the lamp, we do not want to use a restore of any zone, so a "0" will be programmed for the Restore of Zone List (ZL). We will use a **manual entry of User Code + [#] + [8] + Device #** to turn off. Therefore, we do not need to program a STOP event. Press [*] to continue.
- The system will display a summary screen for the START programming for device 01. Press [*] to continue.
- The system will display a summary screen for the STOP programming for device 01. Press [*] to continue.
- The system will display the "X10?" prompt. Enter 1 for yes.
- The **Enter Device No.** prompt for the next zone will be displayed.
- Press 00 and then [*] to exit the *80 mode.
- Now use *81 Zone List mode to program the 3 specific zones in Zone List 1.

Section 19. ZONE LISTS (* 81 Menu Mode)

While in program mode, press *81 to enter Zone List Menu Mode. This mode is used to program zone lists for output devices (programmed in *80 menu mode) and/or for defining a common zone. Refer to the Programming Form worksheet for *81 Mode.

After entering *81, the following prompts are displayed.

Zone List Displays

Zone List No. (00 = Quit) 01	Enter the Zone List Number 01, 02, 03, or 04 to program (or 00 to end these entries). Press the [*] key to advance. In the following displays, zone list 01 has been selected for programming.
01 Enter Zn Num. (00 = Quit) 00	Enter each zone number to add to the zone list by first entering the zone number, then the [*] key (example, 01*, 02*, 03*). After all zones desired are entered, press 00 to advance.
01 Del Zn List? 0 = No 1 = Yes 0	To delete the zone list, enter 1 (Yes). All zones in the zone list will be deleted automatically. and programming will return to the first screen. To save the zone list, enter 0 (No) to advance.
01 Delete Zone? 0 = No 1 = Yes 0	To save the entire zone list, enter 0 (No) and programming will return to the first screen. To delete a zone or zones in a zone list enter 1 (Yes) to advance.
01 Zn to Delete? (00 = Quit) 00	Enter each zone to be deleted from the list, followed by the [*] key. After all zones to be deleted are entered, enter 00 to return to the first screen so that another list can be programmed, if desired.

NOTES:

- Any list may include any or all of the system's zone numbers.
- A zone list can be assigned to more than one output relay.

Section 20.

ALPHA DESCRIPTOR PROGRAMMING

This section provides instructions for programming alpha zone descriptors. This is recommended for systems using Alpha keypads, and necessary if a 4285 Phone Module is used.

If using a 4285 Phone Module, select from those words in the Alpha Vocabulary list shown in **boldface type**. The Phone Module will not provide annunciation of the other words.



If a 4285 Phone Module is added to an existing VISTA-20AMT3 system, the Alpha descriptors presently in the system should be re-programmed, selecting from those words shown in **boldface type** in the Alpha Vocabulary list. The Phone Module will not provide annunciation of any other words.

The ALPHA VOCABULARY LIST and CHARACTER CHART can be found on page 74

Zone Descriptors

The Alpha Keypad used with the *VISTA-20AMT3* can have a user-friendly English language description/location of all protection zones, keypad panics, and RF receiver supervision faults programmed into the system. Each description can be composed of a combination of words (up to a maximum of 3) selected from a vocabulary of 196 words stored in memory (see a following page). In addition, up to 10 installer-defined words can be added to those already in memory. Thus, when an alarm or trouble occurs in a zone, an appropriate description for that zone's location will be displayed at the keypad.

Note: Alpha Descriptor entry can be done locally at the Alpha Keypad or remotely using Downloading software. The Alpha keypad procedure is described below.

Programming Zone Descriptors (program menu mode *82)

The descriptor can be entered when the zone is being defined in field *56 but we recommend that it be done using *82 menu mode.

To program zone descriptors, you simply enter the 3-digit reference number for the desired word(s). The 3-digit number for each word is provided in the Alpha Vocabulary list (on a following page).

1. With the system powered up, enter the programming mode by keying:
Installer code (4 1 1 2) + 8 + 0 + 0. The following display will appear:

Installer Code	20
----------------	----

Program Alpha ?	
0 = No, 1 = Yes	0

Custom Words ?	
0 = No, 1 = Yes	0

2. Press *82.

The "Program Alpha?" prompt will appear.

3. Press "1" (Yes).

The "Custom Words" prompt will appear.

4. Press "0" (No).* The system will then automatically display the descriptor for zone 1.

* The procedure for adding custom words to the built-in vocabulary will be found later under "Adding Custom Words."

Summary Mode Display
Default Descriptor ▼

* ZN 01 ZONE 01

Flashing Cursor (system is ready for entry of word).

* ZN 01

Flashing Cursor ▼

* ZN 01 B ACK

* ZN 01 BACK

▲
Flashing Cursor if "6" is pressed (system is ready for next word).

ZN 01 BACK
 D OOR

▲Flashing Cursor

If a descriptor was not entered previously for zone 1, the default descriptor for zone 1 will be displayed.

Note that this is a "summary mode", and that no entries can be made. Entries can be made only when the display contains a flashing cursor, which signifies the "entry mode."

5. To delete or change the default descriptor for zone 1, press * plus the same zone number (01). This will clear that descriptor and allow changes to be made at the flashing cursor.

NOTE: If you do not wish to change the existing descriptor for zone 1, enter [*] plus the next zone number for which you wish to enter (or check) a descriptor. A summary display for that zone will appear. You must then press [*] plus the same zone number again to gain access to the entry mode (flashing cursor) for that zone.

6. Press [#] plus 3-digit number for the first word from the "Alpha Vocabulary List." Example: The descriptor that we wish to enter for zone 1 is BACK DOOR. From the list, BACK = 013. Therefore, you would enter # 0 1 3.

Note: If you accidentally enter the wrong word, simply press [#] plus the correct 3-digit number for the word you want.

7. Press "6" to accept the selected word and continue.

NOTE: If this is the only word you are using for the descriptor, press "8" instead of "6" to save that word in memory, and then go to step 11.

8. Enter the 3-digit number for the next word. In our example, the word is DOOR, whose number is "057."

Enter # 0 5 7. This display will appear:

* ZN 01 BACK
DOOR



Flashing Cursor if "6" is pressed (system ready for next word).

Summary Display

* ZN 01 BACK
DOOR

Program Alpha ?
0 = No, 1 = Yes 0

Alpha Pgm 82

9. Press "6" to accept the selected word.

NOTE: If these are the only words you are using for the descriptor, press "8" instead of "6" to save them in memory.

10. The two words in our example have now been entered. Note, however, that up to three words may be entered (provided the number of characters will fit on the screen). Press "8" to save all words in memory.

The flashing cursor will disappear, indicating that the word(s) are stored in memory for that zone, as shown in the summary display at the left.

11. To enter a descriptor for the next zone, press * plus the desired zone number (e.g., *02. The summary display following step 4 previously will appear. Now repeat steps 6 through 10 for the descriptor for the next zone.

12. To exit the Alpha descriptor mode, press "*+0+0" at the summary display.

This prompt will be displayed.

13. Press "0." This will be displayed.

14. Press *99 to exit the programming mode.

Adding Custom Words (will not be announced by 4285 Phone Module)

You can add up to 10 installer-defined words to the built-in vocabulary. Each of the 10 "words" can actually consist of a "word string" of one or more words, but no more than *ten* characters can be used for each word or word string.

When adding Custom Words, the keypad keys perform the following functions:

- [4] Moves cursor one space to the left.
- [6] Moves cursor one space to the right.
- [8] Saves the new word in the system's memory.

1. Perform steps 1, 2, and 3 of **Programming the Descriptors** on a previous page.
Select CUSTOM WORD mode (enter "1") when the prompt CUSTOM WORD? is displayed.
2. Enter the number ([01] - [10]) of the custom word or word string to be created (for example, if you are creating the first custom word or word-string, enter [01], for the second, enter [02], etc.). A cursor will now appear at the beginning of the second line.
3. Refer to the CHARACTER LIST of letters, numbers, and symbols on a following page.
Press the [#] key, followed by the two-digit entry for the first letter you would like to display (e.g., [6][5] for "A").
The cursor will then move to the right, in position for the next character.
4. Repeat step 3 to create the desired word(s). Note that the [4] key can be used to move the cursor to the left, if necessary. Remember, no word or word-string can exceed 10 characters.
5. Press the [8] key to save the custom word(s) and return to the "CUSTOM WORD?" display.
Repeat steps 2-5 for other custom words to be entered. To change a custom word, just overwrite it. If no more are to be entered now, press [0] to return to the Descriptor entry. The custom word(s) will be automatically added to the built-in vocabulary.

When zone descriptors are being entered as described in step 6 of **Programming the Descriptors**, the custom word numbers are 245 to 254 for words 1 to 10 respectively as indicated on the next page.

ALPHA VOCABULARY LIST

(For Entering Zone Descriptors)

NOTE: Use only this list when programming VISTA-20AMT3 zone descriptors.

000 (Word Space)	• 064 DUCT	115 LOCK	169 SHOCK	• 227 1
A	E	116 LOOP	• 170 SHOP	• 228 1ST
• 001 AIR	• 065 EAST	117 LOW	171 SHORT	• 229 2
• 002 ALARM	066 ELECTRIC	• 118 LOWER	• 173 SIDE	• 230 2ND
004 ALLEY	067 EMERGENCY	M	174 SKYLIGHT	• 231 3
005 AMBUSH	068 ENTRY	• 119 MACHINE	175 SLIDING	• 232 3RD
• 006 AREA	• 069 EQUIPMENT	121 MAIDS	• 176 SMOKE	• 233 4
• 007 APARTMENT	• 071 EXIT	122 MAIN	• 178 SONS	• 234 4TH
• 009 ATTIC	• 072 EXTERIOR	• 123 MASTER	• 179 SOUTH	• 235 5
010 AUDIO	F	• 125 MEDICAL	180 SPRINKLER	• 236 5TH
B	• 073 FACTORY	126 MEDICINE	• 182 STATION	• 237 6
• 012 BABY	075 FAMILY	128 MONEY	184 STORE	• 238 6TH
• 013 BACK	• 076 FATHERS	129 MONITOR	• 185 STORAGE	• 239 7
• 014 BAR	• 077 FENCE	• 130 MOTHERS	186 STORY	• 240 7TH
• 016 BASEMENT	• 079 FIRE	• 131 MOTION	190 SUPERVISED	• 241 8
• 017 BATHROOM	• 080 FLOOR	132 MOTOR	191 SUPERVISION	• 242 8TH
• 018 BED	081 FLOW	• 134 NORTH	192 SWIMMING	• 243 9
• 019 BEDROOM	082 FOIL	135 NURSERY	193 SWITCH	• 244 9TH
020 BELL	• 083 FOYER	O	194 TAMPER	245 Custom Word #1
• 021 BLOWER	084 FREEZER	• 136 OFFICE	196 TELCO	
• 022 BOILER	• 085 FRONT	• 138 OPEN	197 TELEPHONE	
023 BOTTOM	G	139 OPENING	• 199 TEMPERATURE	246 Custom Word #2
025 BREAK	• 089 GARAGE	• 140 OUTSIDE	200 THERMOSTAT	
• 026 BUILDING	• 090 GAS	142 OVERHEAD	• 201 TOOL	
C	091 GATE	P	202 TRANSMITTER	247 Custom Word #3
028 CABINET	• 092 GLASS	143 PAINTING	U	
• 029 CALL	093 GUEST	• 144 PANIC	• 205 UP	
030 CAMERA	094 GUN	145 PASSIVE	• 206 UPPER	248 Custom Word #4
031 CAR	H	• 146 PATIO	• 207 UPSTAIRS	
033 CASH	• 095 HALL	147 PERIMETER	• 208 UTILITY	
034 CCTV	• 096 HEAT	• 148 PHONE	V	249 Custom Word #5
035 CEILING	098 HOLDUP	150 POINT	209 VALVE	
036 CELLAR	• 099 HOUSE	151 POLICE	210 VAULT	
• 037 CENTRAL	I	• 152 POOL	212 VOLTAGE	250 Custom Word #6
038 CIRCUIT	100 INFRARED	• 153 POWER	W	
• 040 CLOSED	• 101 INSIDE	R	213 WALL	
• 046 COMPUTER	102 INTERIOR	155 RADIO	214 WAREHOUSE	251 Custom Word #7
047 CONTACT	103 INTRUSION	• 156 REAR	• 216 WEST	
D	J	157 RECREATION	• 217 WINDOW	
• 048 DAUGHTERS	104 JEWELRY	159 REFRIGERATION	• 219 WING	252 Custom Word #8
049 DELAYED	K	160 RF	220 WIRELESS	
• 050 DEN	• 105 KITCHEN	• 161 RIGHT	X	
051 DESK	L	• 162 ROOM	222 XMITTER	253 Custom Word #9
• 052 DETECTOR	• 106 LAUNDRY	163 ROOF	Y	
• 053 DINING	• 107 LEFT	S	223 YARD	254 Custom Word #10
054 DISCRIMINATOR	108 LEVEL	164 SAFE	Z	
055 DISPLAY	• 109 LIBRARY	165 SCREEN	224 ZONE (No.)	
• 057 DOOR	• 110 LIGHT	166 SENSOR	• 225 ZONE	
• 059 DOWN	111 LINE	• 167 SERVICE	• 226 0	
• 060 DOWNSTAIRS	• 113 LIVING	• 168 SHED		
061 DRAWER	• 114 LOADING			
• 062 DRIVEWAY				

Note: Bulleted (•) words in **boldface type** are those that are also available for use by the 4285 Phone Module. If using a phone module, and words other than these are selected for Alpha descriptors, the phone module will not provide annunciation of those words.

CHARACTER (ASCII) CHART

(For Adding Custom Words)

32 (space)	42 *	52 4	62 >	72 H	82 R
33 !	43 +	53 5	63 ?	73 I	83 S
34 "	44 ,	54 6	64 @	74 J	84 T
35 #	45 -	55 7	65 A	75 K	85 U
36 \$	46 .	56 8	66 B	76 L	86 V
37 %	47 /	57 9	67 C	77 M	87 W
38 &	48 0	58 :	68 D	78 N	88 X
39 '	49 1	59 ;	69 E	79 O	89 Y
40 (50 2	60 <	70 F	80 P	90 Z
41)	51 3	61 =	71 G	81 Q	

Section 21. USING *83 SEQUENTIAL MODE

Use *83 Sequential mode when a wireless transmitter is to be physically added, removed, or simply changed (as when replacing a unit that has a non-removable battery).

By using this mode, you can add, delete, or change the serial number of a transmitter in a zone, but retain all other existing data that has been programmed for that zone.

Certain button type transmitters have more than one button (e.g., 5801). Note that each button must be assigned to a different zone. Similarly, the 5816 transmitter has contact terminals *and* a reed switch for use with a magnet. If using both, each must also be assigned to a different zone.

This means that the procedures that follow must be repeated for each button or contact on the transmitter.

NOTE: Use this mode only after all other zone information has been programmed, including transmitter loop numbers.

To enroll transmitters **sequentially**, *after* all other zone information has been programmed, do the following:

1. Enter Programming mode [**Installer Code**] + 8 + 0 + 0 on an alpha keypad. Enter Serial Number Sequential mode by pressing *83. The following prompt will be displayed.

NOTE: See the *ZONE PROGRAMMING* section for an explanation of the programming tool.

PROGRAM TOOL?
0 = NO, 1 = YES 0

2. If using a program tool, enter "1." If not using a tool, enter "0." If a tool has already been programmed, this prompt will not appear. If either not using a tool or one has already been programmed, skip to step 4.

00 INPUT S/N: L
Axxx-xxxx

3. If "1" is entered, the system will prompt for the unit's serial number. Enter the program tool's serial number using one of the following methods:

- a) Enter the 7-digit serial number printed on the transmitter
or
- b) Press any button on the transmitter. The keypad should beep twice and display the serial number of the tool.

00 INPUT S/N: L
A123-4567 3

In this example, the serial number is A123-4567. Once enrolled, you can use the program tool to ready the system for enrolling a transmitter's serial number by first pressing the upper left-hand button of the program tool, then activating the desired transmitter (see procedure at the "LEARN S/N?" prompt).

The serial number for the program tool will only remain in the system until the programming mode is exited. (Entering *97 will not delete the tool).

Press [*] to continue.

Press the [#] key on the keypad to back up to the "PROGRAM TOOL?" prompt.

ENTER ZN NUM.
(00 = QUIT) 10

4. Enter the first zone number to be enrolled (e.g., zone 10).

Press [*] to continue.

The system will, starting with this zone number, search for the first transmitter which has *all* of the following attributes pre-programmed in Zone Programming:

- a) An input type of RF, UR, or BR programmed
- b) A loop number programmed
- c) No serial number programmed

Zone Number Entered ▲



If the first zone number entered does *not* have one or more of the above attributes, the system will search its database for the first zone that does and will display it on the next screen.

10 INPUT S/N:L
Axxx xxxx

5. This prompt is displayed when the system has found the next zone which needs to be enrolled. The system will respond to the first serial number transmitted after the [*] key on the keypad is pressed. A serial number may be enrolled by one of two methods:
- Enter the 7 digit serial number printed on the transmitter
or
 - Activate the transmitter by faulting or restoring the input you wish to use for that zone (e.g., press a button, open or close a door, etc.).



If you do *not* wish to enroll the zone displayed, press the [#] key on the keypad or the upper right-hand button on the program tool (a long beep will be heard to verify). The following prompt will appear:

10 LEARN S/N?
0 = NO, 1 = YES 0

To enroll now, enter "1" (YES). If "0" (NO) is entered, the following prompt will appear if a program tool has already been programmed:

ENTER ZN NUM.
(00 = QUIT) 12

Zone Number Entered ▲

Enter the next zone number to be enrolled (e.g., zone 12). The system will search for that zone and will display the prompt shown in the beginning of step 5. If you wish to exit the enroll mode completely, enter 00 and press [*].

10 INPUT S/N:L
A 022-4064 3

▲ ▲
Serial # Loop #

The system will enroll the serial number of the first transmitter heard, add the loop number entered to this serial number, display the serial and loop numbers, and cause the keypad to beep twice.



If the serial and loop number combination is already present in the system, a single long beep will be heard from the keypad. If this happens, the system will not display the serial number, but will wait for a transmission from another transmitter or transmitter loop input.

6. The system will then enter an optional confirmation mode so that the operation of the actual programmed input can be confirmed. Activate the loop input or button that corresponds to this zone. **We recommend that you confirm the programming of every transmitter before proceeding to the next zone.**

10 CONFIRMED
A022-4064 3

When the system sees activity on the appropriate input, it will beep three times and display the confirmation message. Press [*] or the upper left-hand button of the program tool when you are ready to enroll the next transmitter.



At any time during this step, you may press the [*] key on the keypad or the upper left-hand button of the program tool if you are satisfied with the serial and loop number combination that has been enrolled, regardless of whether or not the enrolled input has been "confirmed." This will ready the system to enroll the next transmitter.

If the incorrect transmitter has been enrolled, press the [#] key on the keypad or the upper right-hand button of the program tool to delete the serial number and return to the "LEARN S/N" prompt. A single long beep will be heard from the keypad to verify pressing of the upper right-hand button. Then, press "1" (Yes) or press the upper left-hand button of the program tool (a single short beep will verify the system is ready for enrolling) and re-activate the proper transmitter or transmitter loop input.

7. The system will search for the next zone that does not have a serial number associated with it. If one is found, the prompt in step 5, along with the appropriate zone number, will be displayed. Follow steps 5 and 6 for the remaining wireless zones.

When the last zone has been enrolled, the display will remain on that zone. To exit this mode and return to data field program mode, press [*].



When you have finished programming all zones, test each using the system's TEST mode. Do not use the Transmitter ID Sniffer mode for this, as it will only check for transmission of one zone on a particular transmitter, and NOT the zones assigned to each additional loop.

Section 22. REMOTE PROGRAMMING AND CONTROL (DOWNLOADING)

General Information

The VISTA-20AMT3 can be remotely programmed from an IBM compatible Personal Computer (PC), a HAYES modem, and Ademco's V-LINK® Software (as specified below).

UL

Downloading may only be performed if a technician is at the site.

Programming the control from a remote location is protected against compromise by someone attempting to defeat the system, using multi-levels of security protection:

- 1. Security Code Handshake:** An 8-digit download ID code must be matched between the control and the downloader .
- 2. Site Initiated Remote Programming:** The installer or subscriber initiates the callback from the subscriber premises (by entering Installer code + # + 1) while disarmed. All parameters can then be downloaded via the phone lines using a personal computer.
- 3. Station Initiated Remote Programming:** The operator calls the site from your office to initiate the download call. The control hangs up and then calls back the PC via the preprogrammed telephone number. The unit can then be uploaded, downloaded, or controlled from your office .
- 4. Telco Hand-off:** Allows the installer or subscriber to perform a download session on the call initiated from the site.
- 5. Data Encryption:** Data passed between the PC and the control is encrypted for security so that it is very difficult for a foreign device tapped into the phone line to take over communication and substitute system compromising information.

Equipment Required

At the premises:

- VISTA-20AMT3 and keypad.

At the installer's office/home:

- An IBM PC compatible computer.
- *Either* a HAYES brand SMARTMODEM 1200 [Level 1.2 or higher external or Level 1.1 or higher (with 4 position DIP switch) internal style], *or* a HAYES brand Optima 24 Plus FAX96 Modem.
- V-LINK® Downloading Software Diskette (at revision level supporting the VISTA-20AMT3).
- Appropriate interconnecting cables.

Initial Download

Enter installer code + # + 5. This sets field *95 to 4 rings, and system to "no call-back" option. The download computer can then call the subscriber, make connection, and download all programming items.

Remote Programming Information

The downloading system can perform many functions when in communication with the control unit. Besides uploading and downloading, the status of the system can be observed and various commands can be initiated, as follows:

- Arm the System in the Away Mode; Disarm the System.
- Bypass a Zone.
- Force the System to Accept a New Program Download.
- Shut Down Communication (dialer) Functions (non-payment of monitoring fees in an owned system).
- Shut Down all Security System Functions (non-payment for a leased system).
- Inhibit Local Keypad Programming (prevents account takeover).
- Command the System to Upload a Copy of its Resident Program to the office.
- Read: Arming Status, AC Power Status, Lists of Faulted Zones, Bypassed Zones, Zones Currently in Alarm, Zones Currently in Trouble, and RF Sensors with Low Battery Conditions.

Notes: After the control and the PC have established valid communication, each keypad on the system will become inactive and will display "C C" or "MODEM COMM.." The control, however, will still be scanning its zones and looking for alarms. If an alarm does occur, after communication is broken off, alarms are sounded and the proper dialer reports are sent to the central station. The keypads will become active after the download communication is terminated. The detailed operation of the download functions is covered in the installation instructions for the V-LINK® Downloading Software Diskette.

Remote Programming Advisory Notes

- Alarm and trouble reporting may be delayed during the time that the system and the Downloader are linked to each other following a valid exchange of codes, but the proper message will get through to the Central Station after the link is broken.
- Keypad entries are ignored during the time interval stated above.
- A copy of the program downloaded may be produced from the IBM PC compatible computer, using the product's internal report generator, when an optional printer is connected (consult your PC manual for proper printer and connections).
- Program Upload or Download Time—Approximately one minute fifteen seconds for a complete program.

Section 23. SYSTEM COMMUNICATION

This section provides an explanation of formats this system accommodates for reporting alarms and other system conditions to the central station. The process of a successful transmission consists of both the method of communication between the control panel and the central station receiver and the actual way the information is sent and displayed at the central station.

Report Code Formats

When the panel calls the central station receiver, it waits to hear a "handshake" frequency from the receiver to confirm that the receiver is on-line and ready to receive its message. Once the panel hears the handshake it is programmed to listen for, it sends its message. The panel then waits for a "kissoff" frequency from the receiver acknowledging that the message was received and understood.

If the handshake frequency is not given or is not understood by the panel, the panel will not send its message. Once the handshake frequency is received and understood by the panel, the panel will send its message. If there is an error in the transmission (the receiver does not receive a "valid" message), the kissoff frequency will not be given by the central station receiver.

The panel will make a total of eight attempts to the primary telephone number and eight attempts to the secondary telephone number (if programmed) to get a valid message through. If the panel is not successful after its numerous attempts, the keypad will display "Communication Failure" (Alpha keypad) or "FC" (Fixed-word keypad).

The following chart defines the three sets of (handshake/kissoff) frequencies that the panel supports and the different formats that can be sent for each.

FORMAT	HANDSHAKE	TRANSMITS DATA	KISSOFF	TRANSMIT TIME
Low Speed 3+1 4+1 4+2	1400Hz	1900Hz (10PPS)	1400Hz	Under 15 secs. (Standard report)
Sescoa/Rad 3+1 4+1 4+2	2300Hz	1900Hz (20PPS)	2300Hz	Under 10 secs. (Standard report)
Express 4+2	1400-2300Hz	DTMF (10 cps)	1400Hz	Under 3 secs.
Contact ID	1400-2300Hz	DTMF (10 cps)	1400Hz	Under 3 secs.

The following describes each format in greater detail.

3+1 and 4+1 Standard Formats	Comprise a 3- (or 4-) digit subscriber number and a single digit report code (e.g. Alarm, Trouble, Restore, Open, Close, etc).
3+1 and 4+1 Expanded Formats	Comprise a 3- (or 4-) digit subscriber number, and a two-digit report code. The first digit is displayed on the first line, followed by a second line where the first digit is repeated 3 (or 4) times and followed by the second digit. This is the "expanded" digit.
4+2 Format	Comprises a 4-digit subscriber number and 2-digit report code.
Ademco Contact ID Reporting Format	Comprises a 4-digit subscriber number, 1-digit event qualifier ("new" or "restore"), 3-digit event code, and 3-digit zone number, user number, or system status number (see the following page).

Report	3+1/4+1 Standard	3+1/4+1 Expanded	4+2
Alarm	SSS(S) A	SSS(S) A AAA(A) Z	SSSS AZ
Trouble	SSS(S) T	SSS(S) T TTT(T) t	SSSS Tt
Bypass	SSS(S) B	SSS(S) B BBB(B) b	SSSS Bb
AC Loss	SSS(S) E	SSS(S) E EEE(E) A _C	SSSS EA _C
Low Batt	SSS(S) L	SSS(S) L LLL(L) L _B	SSSS LL _B
Open	SSS(S) O	SSS(S) O OOO(O) U	SSSS OU
Close	SSS(S) C	SSS(S) C CCC(C) U	SSSS CU
Test	SSS(S) G	SSS(S) G GGG(G)g	SSSS Gg
Restore Alarm	SSS(S) R	SSS(S) R RRR(R) Z	SSSS RZ
AC Restore	SSS(S) R _A	SSS(S) R _A R _A R _A R _A (R _A)A _C	SSSSR _A A _C
LoBat Res.	SSS(S) R _L	SSS(S) R _L R _L R _L R _L (R _L)L _B	SSSS R _L L _B
Trouble Res.	SSS(S) R _T	SSS(S) R _T R _T R _T R _T (R _T)t	SSSS R _T t
Bypass Res.	SSS(S) R _B	SSS(S) R _B R _B R _B R _B (R _B)b	SSSS R _B b

Where:

SSS or

SSSS = Subscriber ID

A = Alarm Code-1st digit

Z = Typically Zone Number*-2nd digit

Tt = Trouble Code (1st & 2nd digits)

Bb = Bypass Code (1st & 2nd digits)

EA_C = AC Loss Code (1st & 2nd digits)

LL_B = Low Battery Code(1st & 2nd digits)

O = Open Code-1st Digit

C = Close Code-1st Digit

U = User Number (in hex)

Gg = Test Code (1st & 2nd digits)

R = Restore Code (Alarm)

R_Tt = Restore Code (Trbl)1st & 2nd digits

R_Bb = Restore Code (Byps)1st & 2nd digits

R_AA_C = Restore Code (AC)1st & 2nd digits

R_LL_B = Restore Code (Bat)1st & 2nd digits

Zone numbers for: [] & [#], or [B] = 99 [1] + [*], or [A] = 95 Duress = 92
[3] + [#], or [C] = 96 Tamper = 9

Ademco Contact ID Reporting takes the following format:

CCCC Q EEE ZZZ

where: CCCC = Customer (subscriber) ID

Q = Event qualifier, where:

E = new event , and R = restore

EEE = Event code (3 hexadecimal digits)

Note: For a complete list of event codes, refer to the central office receiver manual.

ZZZ = Zone/contact ID number reporting the alarm, or user number for open/close reports. System status messages (AC Loss, Walk Test, etc.) contain zeroes in the ZZZ location.

TABLE OF CONTACT ID EVENT CODES

Code	Definition
110	Fire Alarm
121	Duress
122	Alarm, 24-hour Silent
123	Alarm, 24-hour Audible
131	Alarm, Perimeter
132	Alarm, Interior
134	Alarm, Entry/Exit
135	Alarm, Day/Night
143	Alarm, Expansion Module
146	Silent Burglary
150	Alarm, 24-Hour Auxiliary
301	AC Power
302	Low System Battery/Battery Test Fail
305	System Reset
333	Trouble or Tamper Expansion Module
351	Telco Line Fault
353	Long Range Radio Trouble
373	Fire Loop Trouble

Code	Definition
374	Exit Error Alarm
380	Global Trouble, Trouble Day/Night
381	RF Supervision Trouble
383	RF Sensor Tamper
384	RF Sensor Low Battery
401	Disarmed, Armed AWAY (MAX), Armed AWAY
406	Cancel by User
407	Remote Arm/Disarm (Downloading)
408	Quick Arm AWAY/MAX
441	Disarmed/Armed STAY/INSTANT, Quick Arm STAY/INSTANT
570	Bypass
602	Periodic Test
606	AAV to follow
607	System Test
623	Event Log 80% Full
629	1-1/3 Day No Event

Section 24. SYSTEM OPERATION

Security Codes

Installer Code

The installer programs the 4-digit Installer Code initially as part of the programming procedure. The factory default Installer code is "4-1-1-2", but may be changed in field *20.

The Installer code is the only code that can enter programming mode and also, in normal operation mode, is used to enter the Master code which allows access to the normal functions of the system.

Master Code

In normal operation mode, the Installer code is used to enter the 4-digit System Master security code using *the connected keypad*. *Therefore:*

To enter the System's Master code, enter:

Installer Code + [8] + [02] + desired 4-digit Master code.

To change the Master code, enter:

Current Master code + [8] + [02] + new Master code + new Master code again

Secondary User Codes

In normal operation mode, the system's Master security code can be used to assign up to 12 secondary 4-digit security codes plus a babysitter code and a duress code. The master code can also be used to remove secondary codes from the system (individually).

To assign (or change) a Secondary security code, enter (*via the systems keypad*):

System's Master Code + [CODE key] + User # (03-16) + desired Secondary Code

The system will emit a single beep when each secondary code has been successfully entered.

To delete a Secondary security code, enter (*via the system's keypad*):

System's Master Code + [CODE key] + User # (03-16)

Notes:

- The Master code and all Secondary security codes permit access to the system for arming, disarming, etc.
- The installer code can disarm the system only if it was used to arm it.
- Babysitter code is User code No. 15; it can disarm the system only if that code (or the installer code) was used to arm it.
- Duress code is User code No. 16. When this is used to perform any system operation, a special code is sent to the monitoring station. Instruct users to be careful not to use this code for normal usage.
- If a secondary code is inadvertently repeated for different users, the lower user number will take priority.
- Opening and closing reports are sent for the Installer code as No. 01, with the appropriate subscriber number. The Master code and secondary user codes are sent as Nos. 02, and 03-16 respectively in Contact ID format (with the appropriate subscriber number); in 4+2, it is 1-F, "F" for anything greater than 14.

Keypad Functions

General Information

Quick arming is always available, therefore the [#] key can be pressed instead of entering the security code, for any of the arming procedures (Away, HOME, INSTANT, etc.). The security code is always required, however, when disarming the system.

The keypad allows the user to arm and disarm the system, and perform other system functions, such as bypassing zones, and display zone descriptors. Zone and system conditions (alarm, trouble, bypass) are displayed in the Display Window.

When an alarm occurs, keypad sounding and external sounding will occur, and the zone(s) in alarm will be displayed on the keypad. Pressing any key will silence the keypad sounder for 10 seconds. Disarming the system will silence both keypad and external sounders. When the system is disarmed, any zones that were in an alarm condition during the armed period will be displayed (memory of alarm). To clear this display, simply repeat the disarm sequence (enter the security code and press the OFF key) again.

The keypads also feature chime annunciation, and 3 panic key pairs, or individual panic keys (depending on keypad type – see *Panic Keys* next page), for silent, audible, fire or personal emergency alarms. These keys can notify the central station of an alarm condition, if that service is connected.

Arming Functions

The following is a brief list of system commands and the resulting keypad displays after entering those commands. For detailed information concerning system functions, refer to the User's Manual.

Disarmed, Not Ready Before arming, the system must be in the ****SYSTEM READY**** condition (all zones must be intact). If the **NOT READY** message appears, press the **READY [*]** key on the keypad to display faulted zones.

Arming Away Enter code + AWAY [2] = **ARMED**AWAY****

Arming Home Enter code + HOME [3] = **ARMED**HOME****

Arming Maximum Enter code + [4] = **ARMED MAXIMUM**
(Ameritech does NOT advertise this capability.)

Arming Instant Enter code + INSTANT [7] = **HOME INSTANT**

Disarming Enter code + OFF [1] = ****SYSTEM READY****

Bypassing Zones Enter code + [6] + zone number(s). = ***ZONE BYPASSED* SYSTEM READY**

Forced (Quick) Bypass ..(If enabled) To automatically bypass all faulted zones, use the "Quick Bypass" method: Enter code + [6], then wait for all open zones to be displayed. Arm when display indicates "bypass" and "ready to arm."

Chime Mode Enter code + CHIME [9] = ***CHIME MODE ON***

To turn chime off, enter code + CHIME again.

The 6139 Alpha keypad contains the following dedicated quick arming keys (not applicable to 5800 series wireless keypads):

A = arm AWAY

B = arm HOME

C = arm HOME INSTANT

D = When pressed, if programmed to do so, will send a special message to a pager and display "Pager Msg sent" on the keypad for 30 seconds.

The message it sends is coded as 999-9999 and signifies ANY message the user and recipient have decided is appropriate such as, "call me at home," "your mother-in-law is coming," etc.

SUMMARY OF ARMING MODES

Arming Mode	Features for Each Arming Mode			
	Exit Delay	Entry Delay	Perimeter Armed	Interior Armed
AWAY	Yes	Yes	Yes	Yes
HOME	Yes	Yes	Yes	No
INSTANT	Yes	No	Yes	No
*MAXIMUM	Yes	No	Yes	Yes

***This feature is not advertised in order to prevent false alarms by the user while at home with ALL protected zones (interior and exterior) armed.**

Panic Keys

There are three panic key pairs that can be used to manually initiate alarms and send a report to the central station.

Each can be individually programmed for 24-hour Silent, Audible, Personal or Fire Emergency responses. The panic function is activated when both keys of the appropriate key pair are pressed at the same time.

The panic functions are identified by the system as follows:

Keys	Displayed as Zone
[1] & [*]	95
[*] & [#]	99
[3] & [#]	96

Important: For the Silent Panic functions to be of practical value, the system must be connected to a central station.

Relay/Powerline Carrier Devices (if used)

If relay outputs (via a 4204, or 4229), or Powerline Carrier devices are used, two keypad entries available to the user are included. They can manually activate or deactivate the device(s) for starting or stopping some action, such as turning lights on or off, etc.

These keypad entries are:

Security Code + [#] + [7] + Device # activates (starts) that device.

Security Code + [#] + [8] + Device # de-activates (stops) that device.

4285 Phone Module (if used)

Refer to the separate instructions supplied with the Phone Module for information concerning its operating procedures.

Note: The Phone Module **cannot** be used to add user codes in this system. User codes must be added by using a wired keypad.

Exit Error Alarm Displays (if programmed)

- A display of "CANCEL ALARM" or "CA" and a zone indication will appear if an exit or interior zone contained a fault during closing at the time the exit delay ended (e.g., exit door left open), **but the system was disarmed during the entry delay time.** The alarm sounder and keypad sound continuously, but stop when the system is disarmed. No message will be transmitted to the central station.
- A display of "EXIT ALARM" or "EA" and a zone indication will appear if an exit or interior zone contained a fault during closing at the time the exit delay ended, **but the system was NOT disarmed during the entry delay time.** The alarm sounder and keypad sound continuously until the system is disarmed (or timeout occurs). An "exit alarm" message is sent to the central station.
- The "EXIT ALARM" display, etc. will also result if an alarm from an exit or interior zone occurs within two minutes after the end of an exit delay.

In any of the above cases, use a second OFF sequence (code plus OFF key) to clear the display.

Trouble Conditions (See Troubleshooting Guide on page 89 also)

General Information

The word "CHECK" on the Keypad's display, accompanied by a rapid "beeping" at the Keypad, indicates that there is a trouble condition in the system. The audible warning sound can be silenced by pressing any key. Instruct users to call for service immediately upon seeing any of the following messages.

"Check" and "Battery" Displays

- A display of "CHECK" and one or more zone numbers indicates that a problem exists with the displayed zone(s) and requires attention.

Note: The control will sense a high resistance in the loops on hard-wired zones 2-8 and display "CHECK" and the affected zone number when the system is in the disarmed mode. It will not be possible to arm the system as long as this condition exists (unless this zone is bypassed). If the system is in the armed mode when the high resistance condition occurs, this display will not appear, but will do so as soon as the system is disarmed. Check the sensor or the loop wiring for the displayed zone.

When the problem has been corrected, the display can be cleared by entering the OFF sequence (code plus OFF key) twice.

- A display of "CHECK" and 09 indicates that communication between control and a zone expander or wireless receiver is interrupted. Check the wiring and DIP switch settings on the units.
- If there are wireless sensors in the system, the CHECK condition may also be caused by some change in the environment that prevents the receiver from receiving signals from a particular sensor.
- A display of "BAT" (Fixed-word keypads) or "SYSTEM LO BAT" (Alpha keypads) with no zone number indicates that the system's main standby battery is weak.
- A display of "BAT" (Fixed-word keypads) or LO BAT (Alpha keypads) with a zone number and a once per minute "beeping" at the keypad indicates that a low battery condition exists in the wireless sensor displayed (zone "00" indicates a wireless keypad). If the battery is not replaced within 30 days, a CHECK display may occur.

Note: Some wireless sensors contain a non-replaceable long-life battery which requires replacement of the entire unit at the end of battery life (e.g., Nos. 5802, 5802CP, 5803).

Telephone Line Failure

A display of "94" (Fixed-word keypads), or "Telco Fault" (Alpha keypads), indicates that a monitored telephone line (if programmed in field *92) has been cut (or disconnected). Depending on how the system was programmed, the keypad may also produce a trouble sound, and the external sounder may be activated (silence by entering installer code plus OFF).

Power Failure

- If there is no keypad display at all, and the POWER indicator (if present) is not lit, operating power for the system has stopped and the system is inoperative.
- If the message "AC LOSS" (Alpha keypads) or "NO AC" (Fixed-word keypads) is displayed, and the POWER indicator (if present) is off, the keypad is operating on battery power only.
- If the battery standby capacity is used up during a prolonged AC power outage, the control's auxiliary power will shut down to minimize deep discharge of the battery.

Other Displays (Fixed Word displays are in parentheses)

Busy-Standby (dI). If this remains displayed for more than 1 minute, the system is disabled.

Modem Comm (CC) The system is in communication with the central station for change of function or status verification.

Comm. Failure (FC) A communication failure has occurred.

Open Circuit (OC) The keypad is not receiving signals from the control and sees an open circuit.

Long Rng Trbl (bF) Back-up LRR communication failure. Refer to LRR installation instructions for four-digit trouble descriptions.

Section 25. TESTING THE SYSTEM

Test Procedure

After installation is completed, the Security System should be carefully tested, as follows.

1. With the System in the disarmed state, check that all zones are intact. If a **NOT READY** message is displayed, press the [*] key to display the faulted zone(s). Restore faulted zone(s) if necessary, so that **READY** message is displayed. Fault and restore every sensor individually to assure that it is being monitored by the system.
2. Enter the **security code** and press the **TEST** key. The outside sounder will sound for 1 second. The keypad should sound 3 beeps each time a contact is faulted. A test report should be transmitted (if programmed) to the Central Station immediately. If the backup battery is discharged or missing, the sounder may not turn on and a **LOW BATTERY** report will be transmitted with a **TEST** report. The keypad will beep once per minute as a reminder that the system is in the Test Mode. To turn off the test mode enter **security code** and press the **OFF** key.

Note: Triggering a zone set to Arm Away, Arm Home, or Disarm will take the system out of **TEST** and cause that action.

Alarm messages will be sent to the central station during the following tests 3 and 4. Notify them in advance that tests will be in progress.

3. Arm the system and fault one or more zones. After 15 seconds (if optional dialer delay is selected), silence alarm sounder(s) by entering the **code** and pressing **OFF**. Check Entry/Exit delay zones.
4. Check the keypad-initiated alarms that are in the system by pressing the Panic key pairs. If the system has been programmed for audible emergency, the keypad will emit a steady alarm sound, and **ALARM and zone number** will be displayed. Silence the alarm by entering the **security code** and pressing **OFF**.
If the system has been programmed for silent emergency, there will be no audible alarms or displays, but a report will be sent to the central station.
5. If output Relay Units/Powerline Carrier Devices have been installed, test their programmed action.
6. Notify the central station when all tests are finished, and verify results with them.
7. To test the wireless part of the system and the RF Receiver, perform the two additional tests that follow:

a. **TRANSMITTER SNIFFER MODE**

Make sure security system is disarmed before trying to enter this mode.

Press **Installer code + # + 3 on keypad**. This initiates a procedure that will check that all transmitters have been properly programmed.

Note: If the communicator is in the process of sending a report to the central station, the system will not go into the Sniffer mode. If so, wait a few minutes, and try again.

The keypads will display all zone numbers of wireless units programmed into the system. As the system receives a signal from each of the transmitters, the zone number of that transmitter will disappear from the display. The transmitter codes may be checked upon installation, or in an installed system.

All the wireless zone numbers should disappear after about 1-1/2 hours.

Notes:

- All BR type units must physically be activated to clear the display.

- When **one** button of a transmitter (RF, UR, or BR) is activated, all zones assigned to other buttons on that transmitter are cleared. This also applies to 5816 and 5817 transmitters which have multiple loops (zones).
- Any transmitter that is not "enrolled" will not turn off its zone number.

Exit this mode by keying **Installer code + OFF**.

- GO/NO GO TEST MODE:** By pressing **Installer code + # + 4 on keypad**, a mode similar to the user test mode (code + TEST) is entered, but the wireless receiver gain is reduced. Checking in this mode assists in determining good mounting locations for the transmitters when the system is being installed and verifies that the RF transmission has sufficient signal amplitude margin for the installed system.

Exit the mode by entering **Installer code + OFF**.

NOTE: **System Test Mode** (code + test) will be **automatically terminated** in approximately 4 hours if the installer or user does not manually terminate it.

This insures that Fire and Panic zones will not remain disabled.

However, **Sniffer Mode** (installer code + # + 3) **does not automatically expire**. You must manually exit (installer code + OFF) sniffer mode to return to normal operation. Sniffer Mode also terminates if a user arms the system.

TO THE INSTALLER

Regular maintenance and inspection (at least annually) by the installer and frequent testing by the user are vital to continuous satisfactory operation of any alarm system.

The installer should assume the responsibility of developing and offering a regular maintenance program to the user as well as acquainting the user with the proper operation and limitations of the alarm system and its component parts. Recommendations must be included for a specific program of frequent testing (at least weekly) to insure the system's proper operation at all times.

Section 26. TROUBLESHOOTING GUIDE

SYSTEM (including Wireless)

SYMPTOM	POSSIBLE CAUSE	REMEDY
1. Transmitter signal not received at 5881/5882.	1a. Transmitter or 5881/5882 not properly powered. 1b. If Transmitter is 5827/5827BD, house code not set in field *24, or transmitter not set to same house code set in that field. 1c. Transmitter located too far from RF receiver. 1d. Metal shielding between transmitter and RF receiver. 1e. Transmitter malfunctioning. 1f. 5881/5882 malfunctioning. 1g. Transmitter No. (zone) not programmed. 1h. 5881/5882 address incorrect. 1i. Field *22 not set properly.	1a. Check or change transmitter's battery. Check VISTA-20AMT3's AC power. 1b. Check code switches inside transmitter. Must match with RF House Code programmed in VISTA-20AMT3. 1c. Move transmitter or RF receiver. 1d. Check for large metal obstructions, then relocate transmitter if necessary. 1e. Verify by activating 5881/5882 with another, similar transmitter. If O.K. now, return defective transmitter. 1f. Verify by making sure other transmitters cannot activate 5881/5882. If defective, replace and return original 5881/5882. 1g. Verify programming. 1h. Set DIP switch on 5881/5882 for address "0." 1i. Set field *22 for "1."
2. Transmitter zone number appears during Transmitter Sniffer mode, but does not clear.	2a. Transmitter zone type (ZT) is set to 00 (Not Used). 2b. Transmitter battery not installed. 2c. 5800 System transmitter not "enrolled" in system.	2a. Set ZT to a valid active zone type in field *56. 2b. Install proper battery. 2c. "Enroll" unit in field *56 or *83.
3. Low Battery message on keypad.	3a. "Bat" or "System Lo Bat" (no zone Nos.) 3b. "Bat" or "Lo Bat" + "00." 3c. "Bat" or "Lo Bat" + "nn."	3a. System battery is low or missing. 3b. Remote RF keypad battery is low. 3c. Transmitter for zone "nn" has a low battery.
4. Periodic beep(s) from keypad.	4a. System is in TEST mode. 4b. A transmitter low battery has occurred and is displayed. 4c. A supervision CHECK has occurred.	4a. Enter "Code" + OFF to exit TEST mode. 4b. Enter "Code" + OFF and replace the battery. 4c. Check the transmitter indicated. Restore communication to the receiver to cancel the condition.
5. With 5800 System, no response to a transmitter in normal operation, although zone number clears during Transmitter Sniffer mode.	Put control in TEST mode. If zone does not respond, try operating the tamper switch or another input to the transmitter. 5a. If another input causes the zone to be displayed, the wrong input was "enrolled" when programming. 5b. If no response at all from this transmitter, this physical transmitter has not been enrolled by the system. Transmitter Sniffer display is being cleared by another unit programmed for this zone.	5a. Delete input's serial number (not the zone), and enroll the proper input (see field *56). 5b. Determine which transmitter is programmed for this zone and reprogram as necessary.
6. Nuisance or phantom alarm.	6a. Sensors not properly installed, wired, or monitored. 6b. Universal transmitter (5817) programmed wrong.	6a. Check installation to see if in accordance with established procedure. 6b. Check programming switches on transmitter.
7. Intrusion alarm for no apparent reason.	7a. Protected door or window opened while system armed. 7b. Improper user operation of exit/entry delays. 7c. Magnets located too far from switches, and/or doors and windows not properly aligned.	7a. Check with all occupants of protected home. 7b. Check setting of entry and exit delays. 7c. Check all openings for proper switch and magnet orientation.
8. "CHECK" and zone number 2-8 is displayed.	8. Control has sensed a high resistance condition on a loop in one of the hard-wired zones (2-8).	8. Check the sensor or the loop wiring in the affected zone. The system will not arm until this condition is corrected (or the affected zone is bypassed).

TROUBLESHOOTING GUIDE (cont'd)

CONTROL

SYMPTOM	POSSIBLE CAUSE	REMEDY
1. "AC POWER" light off.	1a. Interrupted AC power supply.	1a. Check transformer connection and Powerline circuit breaker.
2. Digital communicator message not being received.	2a. VISTA-20AMT3 in TEST mode. 2b. Telephone connection not secure. 2c. Digital communicator malfunctioning. 2d. Telephone number in program needs prefix or access code. 2e. Telephone call to central monitoring station requires operator assistance.	2a. Remove from TEST mode. 2b. Check all connections. 2c. Check with a different VISTA-20AMT3. 2d. Program prefix or access code into the VISTA-20AMT3. 2e. VISTA-20AMT3 system cannot work in this situation.
3. Does not arm properly.	3a. Ready light not on.	3a. Check for faulted zones and make intact, or use Bypass arming, if desired.
4. VISTA-20AMT3 doesn't respond to keystrokes on keypad.	4a. "CC" or "MODEM COMM" displayed. 4b. "d1" or "Busy-Standby" displayed. 4c. "E4" or "E8" displayed. 4d. Keypad address setting incorrect.	4a. System is in communication with downloader at central station. Wait until download session is finished. 4b. System has just been powered and is in its one minute initialization. To bypass this time, press '#' + '0'. 4c. More zones have been programmed than the zone expansion modules can handle. Delete some zones or use a higher capability RF receiver. 4d. Keypads must be set for address 31 (non-addressable mode).

SMOKE DETECTOR

SYMPTOM	POSSIBLE CAUSE	REMEDY
1. Detector alarms, no apparent reason.	1a. Dust, dirt in sensing chamber. 1b. Improper location. 1c. Unit malfunctioning.	1a. Clean unit's sensing chamber with vacuum cleaner per unit's instructions. 1b. See unit's instructions for locations to avoid. Relocate as necessary. 1c. Replace detector.
2. Detector's siren sounds.	2a. Unit not receiving required power. 2b. Unit malfunctioning.	2a. Check for proper installation of battery. Try new battery. 2b. Replace detector.

PLEASE,

Before you call Technical Support, be sure you:

- **READ THE INSTRUCTIONS!**
- **Check all wiring connections.**
- **Determine that the power supply and/or backup battery are supplying proper voltages.**
- **Verify your programming information where applicable.**
- **Note the proper model number of this product, and the version level (if known) along with any documentation that came with the product.**
- **Note your AMERITECH customer number and/or company name.**

Having this information handy will make it easier for us to serve you quickly and effectively.

You may contact Technical Support at the phone number and address given below

Premier Gold Technical Support: 1-800-538-5585 (8 a.m.-6 p.m. E.S.T.)



REGULATORY AGENCY STATEMENTS

UL NOTICE: This is a "Grade A" residential system.

FEDERAL COMMUNICATIONS COMMISSION (FCC) Part 15 STATEMENT

This equipment has been tested to FCC requirements and has been found acceptable for use. The FCC requires the following statement for your information:

This equipment generates and uses radio frequency energy and if not installed and used properly, that is, in strict accordance with the manufacturer's instructions, may cause interference to radio and television reception. It has been type tested and found to comply with the limits for a Class B computing device in accordance with the specifications in Part 15 of FCC Rules, which are designed to provide reasonable protection against such interference in a residential installation. However, there is no guarantee that interference will not occur in a particular installation. If this equipment does cause interference to radio or television reception, which can be determined by turning the equipment off and on, the user is encouraged to try to correct the interference by one or more of the following measures:

- If using an indoor antenna, have a quality outdoor antenna installed.
- Reorient the receiving antenna until interference is reduced or eliminated.
- Move the radio or television receiver away from the receiver/control.
- Move the antenna leads away from any wire runs to the receiver/control.
- Plug the receiver/control into a different outlet so that it and the radio or television receiver are on different branch circuits.

If necessary, the user should consult the dealer or an experienced radio/television technician for additional suggestions. The user or installer may find the following booklet prepared by the Federal Communications Commission helpful: "Interference Handbook"

This booklet is available from the U.S. Government Printing Office, Washington, DC 20402.

The user shall not make any changes or modifications to the equipment unless authorized by the Installation Instructions or User's Manual. Unauthorized changes or modifications could void the user's authority to operate the equipment.

FEDERAL COMMUNICATIONS COMMISSION (FCC) Part 68 STATEMENT

This equipment complies with Part 68 of the FCC rules. On the front cover of this equipment is a label that contains, among other information, the FCC registration number and ringer equivalence number (REN) for this equipment. If requested, this information must be provided to the telephone company.

This equipment uses the following jacks: An RJ31X is used to connect this equipment to the telephone network.

The REN is used to determine the quantity of devices which may be connected to the telephone line. Excessive RENs on the telephone line may result in the devices not ringing in response to an incoming call. In most, but not all areas, the sum of the RENs should not exceed five (5.0). To be certain of the number of devices that may be connected to the line, as determined by the total RENs, contact the telephone company to determine the maximum REN for the calling area.

If this equipment causes harm to the telephone network, the telephone company will notify you in advance that temporary discontinuance of service may be required. If advance notice is not practical, the telephone company will notify the customer as soon as possible. Also, you will be advised of your right to file a complaint with the FCC if you believe necessary.

The telephone company may make changes in its facilities, equipment, operations, or procedures that could affect the operation of the equipment. If this happens, the telephone company will provide advance notice in order for you to make the necessary modifications in order to maintain uninterrupted service.

If trouble is experienced with this equipment, please contact the manufacturer for repair and warranty information. If the trouble is causing harm to the telephone network, the telephone company may request you remove the equipment from the network until the problem is resolved.

There are no user serviceable components in this product, and all necessary repairs must be made by the manufacturer. Other repair methods may invalidate the FCC registration on this product.

This equipment cannot be used on telephone company-provided coin service. Connection to Party Line Service is subject to state tariffs.

This equipment is hearing-aid compatible.

When programming or making test calls to an emergency number, briefly explain to the dispatcher the reason for the call. Perform such activities in the off-peak hours; such as early morning or late evening.

Section 27. SPECIFICATIONS & ACCESSORIES

Specifications

VISTA-20AMT3 SECURITY CONTROL

1. **Physical:** 12-1/2" W x 14-1/2" H x 3" D (318mm x 368mm x 76mm)
2. **Electrical:**
 - VOLTAGE INPUT: 16.5VAC from plug-in 25VA transformer, Ademco No. 1321 (in U.S.A.)
 - RECHARGEABLE BACK-UP BATTERY: 12VDC, 4AH (Gel type). Charging Voltage: 13.8VDC.
 - ALARM SOUNDER: 12V, 2.0 Amp output can drive 12V BELLS or can drive one or two 702 (**series** connected) self-contained 20-watt sirens. Do **not** connect two 702s in parallel.
 - AUXILIARY POWER OUTPUT: 12VDC, 600mA max. Interrupts for 4-wire smoke detector reset.
 - Note:** For UL installations, Alarm Sounder plus Auxiliary Power currents should not exceed 700mA total.
 - STANDBY TIME: (see Table in POWERING THE SYSTEM section)
 - FUSE: Battery (3A) No. 90-12
3. **Communication:**
 - FORMATS SUPPORTED:
 - Ademco Express,**
10 characters/sec, DTMF (TouchTone) Data Tones, 1400/2300Hz ACK, 1400Hz KISSOFF.
 - Ademco Contact ID Reporting,**
10 characters/sec., DTMF (TouchTone) Data Tones, 1400/2300Hz ACK, 1400Hz KISSOFF.
 - Ademco Low Speed,** 10 pulses/sec, 1900Hz Data Tone, 1400Hz ACK/KISSOFF.
 - Radionics/SESCOA,** 20 pulses/sec, 1800Hz Data Tone, 2300Hz ACK/KISSOFF. Can report 0-9, B-F
 - Line Seize: Double Pole
 - Ringer Equivalence: 0.7B
 - FCC Registration No.: AC 398U-68192-AL-E
4. **Maximum Zone Resistance:** Zones 1-8 = 300 ohms excluding EOLR

6128AMT3 REMOTE KEYPAD

1. **Physical:** 5-3/4" W x 4-3/4" H x 1" D (146mm x 121mm x 26mm)
2. **Electrical:** Voltage Input: 12VDC; Current Drain: 30mA
3. **Interface Wiring:** To control panel's keypad connection points as follows:
 - RED: 12VDC input (+) aux pwr
 - GREEN: Data Out to Control
 - YELLOW: Data In from Control
 - BLACK: Ground

**6139AMT3
REMOTE KEYPAD**

1. **Physical:** 6-1/4" W x 4-3/4" H x 1" D (159mm x 121mm x 26mm)
2. **Electrical:** Voltage Input: 12VDC; Current Drain: 100mA
3. **Interface Wiring:** Same as 6128AMT3.

**5881/5882 SERIES
RF RECEIVERS
(5800 System)**

1. **Physical:** 7-3/8" (188mm) W x 4-3/8" (112mm) H x 1-7/16" (37mm) D
Note: 10-7/8" (277mm) H with antenna
2. **Electrical:** Voltage Input: 12VDC; Current Drain: 35mA
3. **Interface Wiring:** Same as 6128AMT3..
4. **Range:** 200ft (60m) nominal indoors from wireless transmitters (the actual range to be determined with system in TEST mode).
5. **Zones:** (With the **VISTA-20AMT3**)
5881L/5882L: accepts up to 8 transmitters
5881M/5882M: accepts up to 16 transmitters
5881H/5882H: accepts up to 30 transmitters

**5800TM
TRANSMITTER
MODULE
used with 5827BD
Wireless 2-Way Keypad**

1. **Physical:** 2-1/4" W x 4-1/8" H x 7/8" D (57mm x 105mm x 22mm)
2. **Electrical:** Voltage Input: 12VDC Current Drain: 20mA
3. **Interface Wiring:** Same as 6128AMT3..

**4219
WIRED EXPANSION
MODULE**

1. **Physical:** 6-1/2" W x 4-1/4" H x 1-1/4" D (169mm x 108mm x 32mm)
2. **Electrical:** Voltage Input: 12VDC; Current Drain: 35mA
3. **Interface Wiring:** Same as 6128AMT3..
4. **8 EOLR Loops (A-H):** Loop A can be set for fast (10-15msec) response to an open.

**4204
RELAY MODULE**

1. **Physical:** 6-1/2" W x 4-1/4" H x 1-1/4" D (169mm x 108mm x 32mm)
2. **Electrical:** Voltage Input: 12VDC; Current Drain: 15mA(Relays off)
180mA (Relays on)
3. **Interface Wiring:** Same as 6127
4. **Four Output Relays:** SPDT Contacts,
Rating: 2A max at 28VDC/AC

**4229
WIRED EXPANSION/
RELAY MODULE**

1. **Physical:** 6-1/2" W x 4-1/4" H x 1-1/4" D (169mm x 108mm x 32mm)
2. **Electrical:** Voltage Input: 12VDC; Current Drain: 35mA (Relays off)
100mA (Relays on)
3. **Interface Wiring:** Same as 6128AMT3..
4. **8 EOLR Loops (A-H):** Loop A can be set for fast (10-15msec) response to an open.
5. **Two Output Relays:** SPDT Contacts, Rating: 2A max at 28VDC/AC

**4285
PHONE MODULE**

1. **Physical:** 6-1/2" W x 4-1/4" H x 1-1/4" D (169mm x 108mm x 32mm)
2. **Electrical:** Voltage Input: 12VDC Current Drain: 160mA
3. **Device Address:** Permanently set to address 4.
4. **Interface Wiring:** See 4285 PHONE MODULE section on pages 32 thru 35 inclusive.
5. **Telephone Line Connections:** See 4285 PHONE MODULE section on pages 32 thru 35 inclusive.

**4286VIP
PHONE MODULE**

1. **Physical:** 6-1/2" W x 4-1/4" H x 1-1/4" D (169mm x 108mm x 32mm)
2. **Electrical:** Voltage Input: 12VDC Current Drain: 300mA
3. **Device Address:** Permanently set to address 4.
4. **Interface Wiring:** See 4286VIP PHONE MODULE section on pages 32 thru 35 inclusive.
5. **Telephone Line Connections:** See 4285 PHONE MODULE section on pages 32 thru 35 inclusive.

Accessories (Compatible Devices)

No. 1321 16.5VAC, 25VA Plug-In Transformer
 No. 4300 Powerline Carrier device Interface AC Transformer

Sounders

Ademco AB-12M 10" Motorized Bell & Box Motor bell & box. UL Grade A. 100 mA current draw.

Ademco 1011BE12M 10" Motorized Bell & Box Motor bell & box. UL Listed. 100 mA current draw.

Ademco 702 Outdoor Siren Self-contained 6–12 volt siren (driver built-in) and weatherproof for outdoor use. Can be wired for either a steady or warble sound.

Ademco 719 2-Channel Siren Two-channel, self-contained 6–12-volt siren (driver built in). 109dB @ 10 feet. 550mA current draw.

Ademco 747 Indoor Siren Self-contained 12 volt siren (driver built-in) for indoor wall mount. 747F available for flush mounting.

Ademco 747UL Indoor Siren Self-contained siren (driver built-in) for indoor wall mount. UL Listed.

Ademco 744 Siren Driver 6 jumper-selected sound outputs. Rated at 119dB with use of an 8-ohm 30 watt speaker.

Ademco 745X3 Voice Siren Driver Voice siren driver with English, Spanish and French voice messages. Separate messages for Fire and Burglary. Use with 8-ohm speaker. UL Listed.

Ademco 705–820, 5-inch Round Speaker 15-watt, 8-ohm speaker.

Ademco 713 Speaker 40-watt, 8-ohm, indoor/outdoor speaker.

System Sensor PA400B (beige)/PA400R (red) Indoor Piezo Sounder Indoor piezo sounder (red or beige), rated at 90 dB @ 10 feet.

Compatible 2-Wire Smoke Detectors

System Sensor

2300T Photoelectric w/heat sensor, direct wire
 2400 Photoelectric, direct wire
 2400TH Photoelectric w/heat sensor, direct wire
 2451 Photoelectric w/B401B base
 2451TH Photoelectric w/heat sensor & B401Bbase
 1400 Ionization, direct wire
 1451 Ionization w/B401B base
 2451 Photoelectric duct detector w/DH400 base
 1451DH Ionization duct detect. w/DH400 base

Compatible 4-Wire Smoke/Combustion Detectors

System Sensor

1412 4-wire ionization products of combustion detector
 2412 4-wire photoelectric smoke detector
 2412TH 4-wire photoelectric smoke detector w/135° F (57° C) heat detector
 A77–716B EOL relay module (supervisory module for wired 4-wire fire zone).
 2112/24T Low-profile 4-wire photoelectric smoke detector w/135° F (57° C) heat detector

APPENDIX A.

5800 RF System Wireless Transmitters

Transmitter Input Loop Identification

5800 Series Transmitter Input Loop Identification

- All of the transmitters illustrated below have one or more unique factory assigned input (loop) ID codes. Each of the input loops requires its own programming zone (e.g., a 5804's four inputs require four programming zones).

- Transmitter inputs entered as:

"RF" (Supervised RF) Type send periodic check-in signals, as well as fault, restore and low battery signals. The transmitter must remain within the receiver's range.

"UR" (Unsupervised RF) Type send all the signals that the "RF" Type does, but the control does not supervise the check-in signals. The transmitter may, therefore, be carried off-premises.

"BR" (Unsupervised Button RF) Type only send fault signals. They do not send low battery, restore or check-in signals. The transmitter may be carried off-premises.

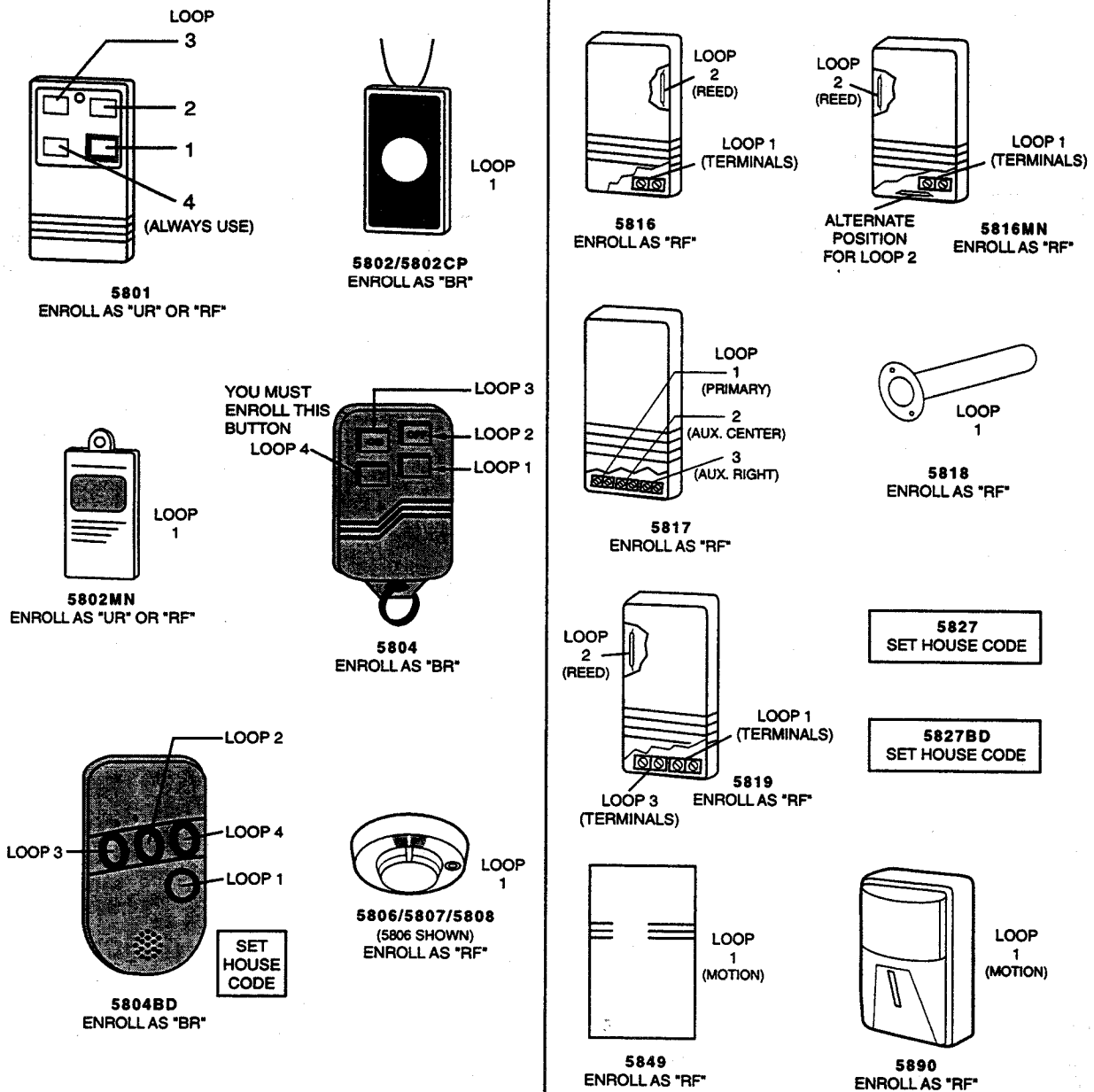

1-minute delay	45
1011BE12M	36
1321	9, 12, 45
1321 AC transformer	8
1321 transformer	30
1400	95
1412	19, 95
1451	95
1451DH	95
15-SECOND DIALER DELAY (BURGLARY) ..	55
2-digit phone code	35
2112/24T	19, 95
2300T	95
24-hour	50
24-hour Audible Alarm	50
24-hour Silent Alarm	50
2400	95
2400TH	95
2412	19, 95
2412TH	19, 95
2451	95
2451TH	95
3+1 and 4+1 Expanded Formats	81
3+1 and 4+1 Standard Formats	81
3+1 or 4+1 Standard Format	56
3-digit number	70, 71
4+2 Format	81
4-wire smoke detectors	17
4142TR cable	13, 31, 39
4146	39
4204	8, 29, 43, 48, 67, 85, 94
4219	7, 21, 22, 29, 94
4229	7, 8, 21, 22, 29, 43, 48, 67, 85, 94
4285	12, 32, 33, 34, 35, 43, 73, 94
4285 Phone Module	8, 70
4300 transformer	8, 12, 29, 30
487-12	15
488-12	15
5137TRK	15
5800 series transmitters	25, 28
5800TM	25, 94
5801	25, 26, 75
5802	25, 26, 86
5802CP	25, 26, 27, 86
5802MN	25
5803	25, 26, 86
5804, 5803	25
5816	25, 75
5817	25, 89
5818	27
5827	23, 25, 28
5827/5827BD	89
5827BD	23, 25, 94
5849	27
5881(5882 in Canada)	7
5881/5882	23
5881/5882 SERIES	94
5881/5882.	89
5881H	7, 23
5881H (5882H in Canada)	23
5881L	7
5881L (/5882L up to 8)	23
5881M	7, 23

5890	27
6127 7	
6128AMT3	14, 15, 94
6137 7	
6137	
6138	
6139AMT3	7, 14, 15, 47, 94
6139TRK	15
702	95
705-820	95
713	95
719	95
744	95
745X3	95
747	95
747UL	95
7720 PLUS or 7820	38
7720PLUS or 7820	9
9-pin connector	39
A77-716B	19, 95
AC LOSS REPORT CODE	57
AC Power Supply	9
AC RESTORE REPORT CODE	58
AC Transformer	12
addressable keypads	14, 32
addressable type keypads	15
Ademco	36
Ademco 744	36
Ademco 745X3	36
Ademco 747	36
Ademco AB-12M	95
Ademco AB-12M 10" Motorized Bell & Box	36
Ademco Contact ID	9, 81
Ademco Express	9, 93
Ademco Low Speed	9, 93
ALARM BELL TIMEOUT	53
Alarm Output	9, 37, 46
ALARM RESTORE RPRT CODE, 1st DIGIT ..	58
alarm sounders	37
Alpha	48
Alpha descriptor	72
Alpha keypad	48
Alpha Keypads	7
Alpha Vocabulary	70
Alpha Vocabulary List	71
answering machine	60
ARM AWAY/HOME REPORT CODE	57
Arming Away	84
Arming Instant	84
Arming HOME	84
Arm-AWAY	50
Arm-HOME	50
ATLIS-BBS	91
AUDIBLE EXIT WARNING	53
Audio Alarm Verification	8, 43
Audio Alarm Verification (AAV)	32
Auxiliary Output	46
Auxiliary Power Output	9
Baby-sitter Code	8
Back-Up Battery	9, 13, 45
backup battery	37
Basic Hardwired Zones	7
battery connector cable	46

Battery Life	26	EXIT ERROR REPORT CODE	57
Battery Size	45	Expanded or 4+2 Format	56
battery standby formula	46	Factory Defaults	48
bells	7	fast busy signal	34
button transmitters	25	FCC	92
button type transmitters	75	Fire alarm sounding	18
BYPASS REPORT CODE	57	FIRE SOUNDER TIMEOUT	52
BYPASS RESTORE REPORT CODE	58	Fixed-Word Keypads	7
Bypassing Zones	84	Forced (Quick) Bypass	84
cabinet lock	10	FORCED BYPASS	47
Caller ID unit	33, 34	FORCED BYPASS FUNCTION	51
CANCEL REPORT CODE	58	formats	80
central station	56	FUSE	93
CHARACTER (ASCII) CHART	74	Go/No Go Test Mode	28, 88
CHARACTER CHART	70	handshake	80
CHARACTER LIST	73	hard-wired zones	17
Charging Voltage	93	HAYES modem	9, 78
check-in signal	25	HAYES Modem	78
Check-Out Procedure For Hard-Wired Zones ..	20	House ID	23, 28
Chime Mode	84	House Identification	23
Communication	93	IBM compatible Personal Computer (PC)	78
communication failure	86	IBM personal computer	47
Communication Formats Supported	9	Ideal Model 61-035	13, 45
COMPATIBLE 2-WIRE SMOKE		IEI 735L series detectors	19
DETECTORS	18, 95	indicator panel	39
COMPATIBLE 4-WIRE SMOKE/COMBUSTION		INITIALIZE DOWNLOAD ID	60
DETECTORS	19, 95	Input Device types	62
Compatible Glass Break Detectors	19	INSTALLER CODE	47, 51
compatible sounders	36	interactive mode	25
CONFIRMATION OF ARMING DING	53	interactive programming	41
Contact ID	38, 56, 82	Interior w/Delay	50
CONTACT ID EVENT CODES	82	Interior, Follower	49
Contact ID Reporting	93	Keypad Connections	15
control cabinet	10	Keypad Panic Keys	8
Control's Circuit Board	11	keypads	14, 15
Custom Words	73, 74	keyswitch	39
Default Descriptor	71	KEYSWITCH ENABLE	52
Default values	62	keyswitch operation	42
device address	21	kissoff	80
DIALER PROGRAMMING	54	LED indications	42
DIP switch	21, 24, 29	LEDs	39
DIP switches	25, 28	line seizure wiring	34
Disarm	50	Lock	10
Disarmed, Not Ready	84	lock switch	39
Disarming	84	Long Range Radio	9, 38
DOWNLOAD INFORMATION	59	LOW BAT REPORT CODE	57
DOWNLOAD PHONE NUMBER	59	LOW BAT RESTORE REPORT CODE	58
downloader	25	low battery message	46, 89
Duress Code	8	LRR communication failure	86
Eagle 1241	43	magnet	75
Earth Ground	13, 45	Magnets	89
enroll	62	main PC board	10
enrolled	25	Master code	83
enrolling	26	model 112	39
entry delay	1	modem	47
Entry/Exit Burglary	1, 2	momentary switch	39
EOL resistor	17, 18, 20, 22, 39	monitored telephone line	86
EOL resistors	16	No Alarm Response	50
EOL supervision	25	No. 1321	95
EOLR	21, 39	No. 4300	95
EVENT LOG 80% FULL REPORT CODE	58	No. 467 (12V, 4AH) battery	45
Event Logging	9, 59	No. A77-716B	18
Exit Error Alarm	85	non-removable battery	75

NUMBER OF REPORTS	59	Secondary User Codes	83
Off-Premises Phone	35	Security Codes	83
On-Premises Phone	35	Sequential mode	60, 75
OPEN REPORT CODE	57	numbers	48
Optima 24 Plus FAX96 Modem	78	serial number	75, 89
OPTION SELECTION	59	Sescoa/Radionics	9
Output Devices	65	SESCOA/RADIONICS SELECT	56
Output Relays	8, 67	SET ALL PROGRAM FIELDS	60
OUTPUT TO LONG RANGE RADIO	52	Silent Burglary	50
PA400B	95	Silent Panic	85
PA400R	36, 95	SINGLE ALARM SOUNDING PER ZONE	52
PABX ACCESS CODE	54	sirens	37
PAGING FORMAT	58	SMARTMODEM 1200	78
Panic Keys	85	Sounders	95
Perimeter Burglary	49	SPLIT/DUAL REPORTING	55
PERIODIC TEST REPORT	55	Supervised Fire	50
Phone Line	12	Supervised RF	26
PHONE LINE MONITOR ENABLE	59	Supplementary Power Supply	15
Phone Module	12, 33, 34, 60, 85	SYSTEM COMMUNICATION	80
PHONE MODULE ACCESS CODE	52	SYSTEM OPERATION	67
Phone Module	32	System Sensor PA400B	36
PHONE SYSTEM SELECT	54	system status and restore REPORT CODES	56
Power Failure	86	SYSTEM STATUS REPORT CODES	57
POWER LED	45	table	12
POWER UP IN PREVIOUS STATE	53	tamper protection	21, 25
Powerline Carrier device	68	tamper switch	39
HOUSE ID	52	TECHNICAL SUPPORT CONTACT	91
Powerline Carrier devices	9, 29, 30, 67, 85	Telco line	34
Powerline Carrier Devices (X-10 type)	8	Telephone Line Monitoring	9
PRIMARY PHONE No.	54	Test Mode	87
PRIMARY SUBS ACCOUNT. No.	54	TEST REPORT CODE	57
Program Upload or Download Time	79	TEST REPORT OFFSET	56
Programming Hard-Wired Zones	20	TEST RESTORE REPORT CODE	58
Programming Information	47	Touch-tone	32
PULSE dialing,	32	TouchTone phone	35
Quick arming	84	Transmitter Input Types	26
Radionics/SESCOA	93	Transmitter Sniffer Mode	26, 87, 89
"READY" LED	45	Transmitter Supervision	25
Receiver Supervision	23	Trouble by Day	49
reed switch	75	trouble condition	86
Relay outputs	29	TROUBLE REPORT CODE	57
Relay Programming	48	TROUBLE RESTORE REPORT CODE	58
Relays	29	UL	13, 15, 25, 30, 36, 38, 46, 92, 93
Remote Keypads	7	Unsupervised Button	26
REMOTE PROGRAMMING	78	unsupervised RF	25, 26
Report code	57, 62	V-LINK® Downloading Software Diskette	79
Report Code Formats	80	V-LINK® Software	78
report codes	56	Verify® Operation of	17
REPORT FORMAT	54	VOCABULARY LIST	74
response time	42, 62	Wired Expansion	7
RESTORE	58	WIRED ZONE EXPANSION	47, 48, 51
RF House ID	25	Wireless Expansion	7
RF HOUSE ID CODE	51	wireless transmitter	75
RF interference	23	wireless transmitters	23
RF "keys"	25	wireless zones	23
RF Receiver	23	Wiring 2-Wire Smoke Detector	17
RF SYSTEM	47, 48, 51	Wiring 4-Wire Smoke/Combustion Detectors	
RF XMTR LOW BATTERY REPORT CODE	58	on Zones 2-7	18
RF XMTR LOW BATTERY RESTORE CODE	58	wiring length/gauge chart	14
RING DETECTION COUNT FOR		Wiring Run Chart	14
DOWNLOADING	60	word string	73
RJ31X jack	12, 33, 34	WORKSHEET	46
SECONDARY PHONE No.	54	X-10 brand devices	29

X-10 type	9
X-10	68
Zone Descriptors	9
Zone Descriptors	74
Zone Expansion	21
Zone List	48
Zone Not Used	49
Zone Programming	48
zone type	62
Zone Type Default	62
Zone types	49, 67

- NOTES -

WARNING

THE LIMITATIONS OF THIS ALARM SYSTEM

While this System is an advanced design security system, it does not offer guaranteed protection against burglary, fire or other emergency. Any alarm system, whether commercial or residential, is subject to compromise or failure to warn for a variety of reasons. For example:

- Intrusion detectors (e.g., passive infrared detectors), smoke detectors, and many other sensing devices will not work without power. Battery-operated devices will not work without batteries, with dead batteries, or if the batteries are not put in properly. Devices powered solely by AC will not work if their AC power supply is cut off for any reason, however briefly.
- Signals sent by wireless transmitters may be blocked or reflected by metal before they reach the alarm receiver. Even if the signal path has been recently checked during a weekly test, blockage can occur if a metal object is moved into the path.
- A user may not be able to reach a panic or emergency button quickly enough.
- While smoke detectors have played a key role in reducing residential fire deaths in the United States, they may not activate or provide early warning for a variety of reasons in as many as 35% of all fires, according to data published by the Federal Emergency Management Agency. Some of the reasons smoke detectors used in conjunction with this System may not work are as follows. Smoke detectors may have been improperly installed and positioned. Smoke detectors may not sense fires that start where smoke cannot reach the detectors, such as in chimneys, in walls, or roofs, or on the other side of closed doors. Smoke detectors also may not sense a fire on another level of a residence or building. A second floor detector, for example, may not sense a first floor or basement fire. Finally, smoke detectors have sensing limitations. No smoke detector can sense every kind of fire every time. In general, detectors may not always warn about fires caused by carelessness and safety hazards like smoking in bed, violent explosions, escaping gas, improper storage of flammable materials, overloaded electrical circuits, children playing with matches, or arson. Depending on the nature of the fire and/or location of the smoke detectors, the detector, even if it operates as anticipated, may not provide sufficient warning to allow all occupants to escape in time to prevent injury or death.
- Passive Infrared Motion Detectors can only detect intrusion within the designed ranges as diagrammed in their installation manual. Passive Infrared Detectors do not provide volumetric area protection. They do create multiple beams of protection, and intrusion can only be detected in unobstructed areas covered by those beams. They cannot detect motion or intrusion that takes place behind walls, ceilings, floors, closed doors, glass partitions, glass doors, or windows. Mechanical tampering, masking, painting or spraying of any material on the mirrors, windows or any part of the optical system can reduce their detection ability. Passive Infrared Detectors sense changes in temperature; however, as the ambient temperature of the protected area approaches the temperature range of 90° to 105°F (32° to 40°C), the detection performance can decrease.
- Alarm warning devices such as sirens, bells or horns may not alert people or wake up sleepers if they are located on the other side of closed or partly open doors. If warning devices are located on a different level of the residence from the bedrooms, then they are less likely to waken or alert people inside the bedrooms. Even persons who are awake may not hear the warning if the alarm is muffled by noise from a stereo, radio, air conditioner or other appliance, or by passing traffic. Finally, alarm warning devices, however loud, may not warn hearing-impaired people.
- Telephone lines needed to transmit alarm signals from a premises to a central monitoring station may be out of service or temporarily out of service. Telephone lines are also subject to compromise by sophisticated intruders.
- Even if the system responds to the emergency as intended, however, occupants may have insufficient time to protect themselves from the emergency situation. In the case of a monitored alarm system, authorities may not respond appropriately.
- This equipment, like other electrical devices, is subject to component failure. Even though this equipment is designed to last as long as 20 years, the electronic components could fail at any time.

The most common cause of an alarm system not functioning when an intrusion or fire occurs is inadequate maintenance. This alarm system should be tested weekly to make sure all sensors and transmitters are working properly. The security keypad (and remote keypad) should be tested as well.

Wireless transmitters (used in some systems) are designed to provide long battery life under normal operating conditions. Longevity of batteries may be as much as 4 to 7 years, depending on the environment, usage, and the specific wireless device being used. External factors such as humidity, high or low temperatures, as well as large swings in temperature, may all reduce the actual battery life in a given installation. This wireless system, however, can identify a true low battery situation, thus allowing time to arrange a change of battery to maintain protection for that given point within the system.

Installing an alarm system may make the owner eligible for a lower insurance rate, but an alarm system is not a substitute for insurance. Homeowners, property owners and renters should continue to act prudently in protecting themselves and continue to insure their lives and property.

We continue to develop new and improved protection devices. Users of alarm systems owe it to themselves and their loved ones to learn about these developments.

Figure 22. VISTA-20AMT3 SUMMARY OF CONNECTIONS

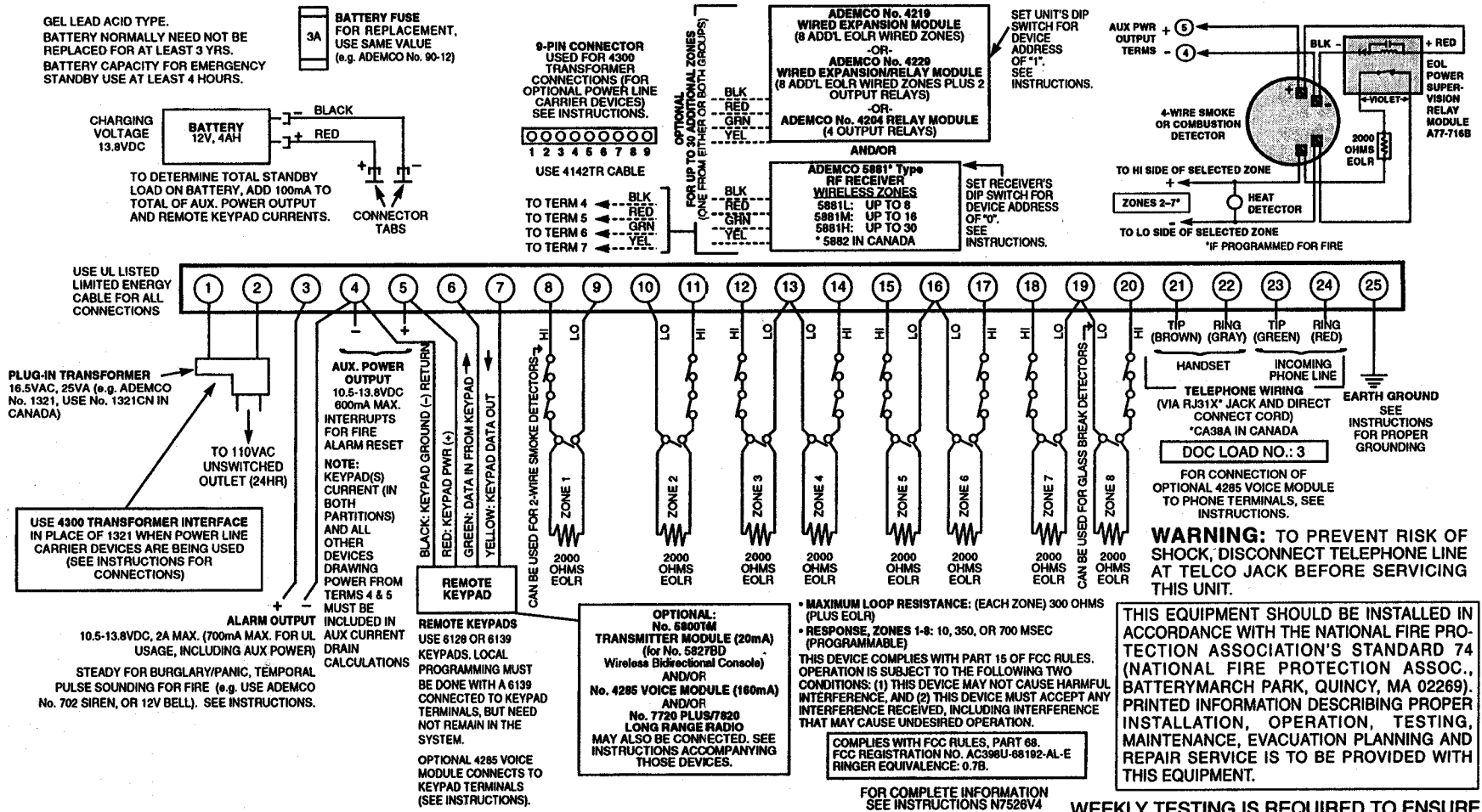

ADEMCO LIMITED WARRANTY

Alarm Device Manufacturing Company, a Division of Pittway Corporation, and its divisions, subsidiaries and affiliates ("Seller"), 165 Eileen Way, Syosset, New York 11791, warrants its products to be in conformance with its own plans and specifications and to be free from defects in materials and workmanship under normal use and service for 24 months from the date stamp control on the product or, for products not having an Ademco date stamp, for 12 months from date of original purchase unless the installation instructions or catalog sets forth a shorter period, in which case the shorter period shall apply. Seller's obligation shall be limited to repairing or replacing, at its option, free of charge for materials or labor, any product which is proved not in compliance with Seller's specifications or proves defective in materials or workmanship under normal use and service. Seller shall have no obligation under this Limited Warranty or otherwise if the product is altered or improperly repaired or serviced by anyone other than Ademco factory service. For warranty service, return product transportation prepaid, to Ademco Factory Service, 165 Eileen Way, Syosset, New York 11791.

THERE ARE NO WARRANTIES, EXPRESS OR IMPLIED, OF MERCHANTABILITY, OR FITNESS FOR A PARTICULAR PURPOSE OR OTHERWISE, WHICH EXTEND BEYOND THE DESCRIPTION ON THE FACE HEREOF. IN NO CASE SHALL SELLER BE LIABLE TO ANYONE FOR ANY CONSEQUENTIAL OR INCIDENTAL DAMAGES FOR BREACH OF THIS OR ANY OTHER WARRANTY, EXPRESS OR IMPLIED, OR UPON ANY OTHER BASIS OF LIABILITY WHATSOEVER, EVEN IF THE LOSS OR DAMAGE IS CAUSED BY THE SELLER'S OWN NEGLIGENCE OR FAULT.

Seller does not represent that the products it sells may not be compromised or circumvented; that the products will prevent any personal injury or property loss by burglary, robbery, fire or otherwise; or that the products will in all cases provide adequate warning or protection. Customer understands that a properly installed and maintained alarm may only reduce the risk of a burglary, robbery, fire or other events occurring without providing an alarm, but it is not insurance or a guarantee that such will not occur or that there will be no personal injury or property loss as a result. CONSEQUENTLY, SELLER SHALL HAVE NO LIABILITY FOR ANY PERSONAL INJURY, PROPERTY DAMAGE OR OTHER LOSS BASED ON A CLAIM THE PRODUCT FAILED TO GIVE WARNING. HOWEVER, IF SELLER IS HELD LIABLE, WHETHER DIRECTLY OR INDIRECTLY, FOR ANY LOSS OR DAMAGE ARISING UNDER THIS LIMITED WARRANTY OR OTHERWISE, REGARDLESS OF CAUSE OR ORIGIN, SELLER'S MAXIMUM LIABILITY SHALL NOT IN ANY CASE EXCEED THE PURCHASE PRICE OF THE PRODUCT, WHICH SHALL BE THE COMPLETE AND EXCLUSIVE REMEDY AGAINST SELLER. This warranty replaces any previous warranties and is the only warranty made by Seller on this product. No increase or alteration, written or verbal, of the obligations of this Limited Warranty is authorized.



*Two Mid America Plaza
Suite 200
Oakbrook Terrace, Illinois, 60181*